

MINOLTA SRT 101

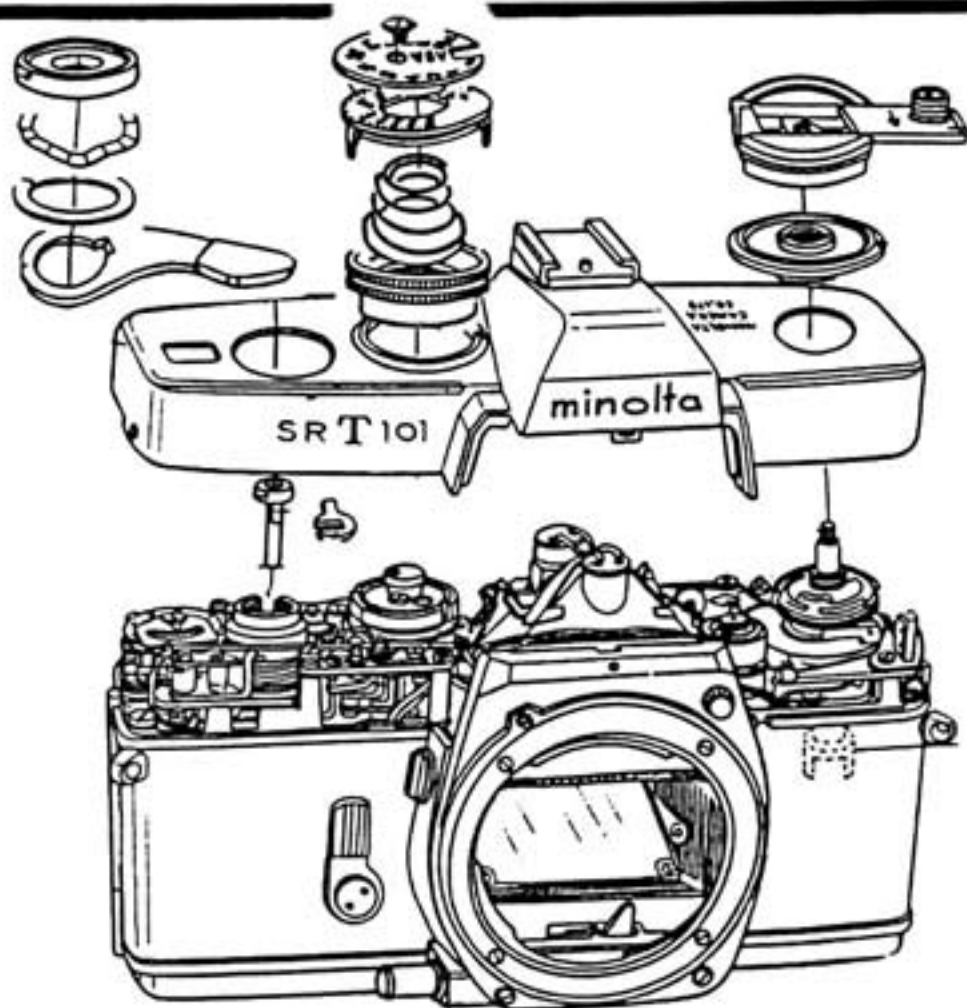

SERVICE MANUAL

Assembly and Mounting

A. Mounting of Top cover	25
B. Mounting of Bottom cover.....	25
C. Assembly and mounting of Viewfinder and meter block.....	27
D. Mounting of Self-gear and Mirror box	32
E. Mounting of Front base frame.....	35
F. Mounting of Following base plate.....	38
G. Mounting of Aperture reducing base plate.....	43
H. Mounting of Shutter base plate-A and slow-gear.....	45
I. Mounting of Winding base plate	49
J. Mounting of Film take-up spool	51
K. Mounting of Shutter base plate-B	53
L. Mounting of Shutter curtains	58
M. Assembly of Inner barrel	60
N. Assembly of Outer barrel.....	62
O. Mounting of Inner and outer barrels	64
P. Mounting of Sprocket.....	66

DISASSEMBLY SECTION



Fig. 1

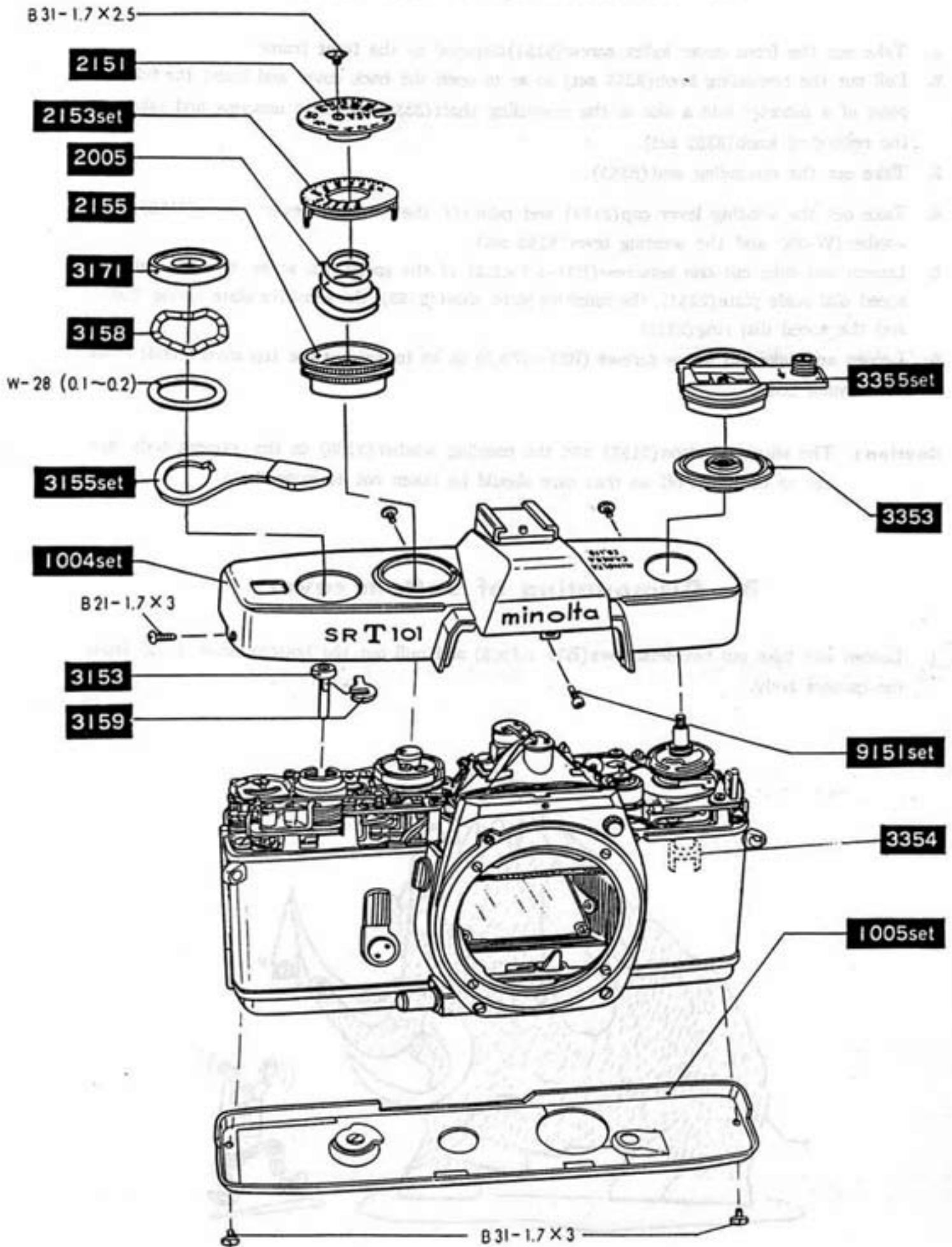

A. Dismounting of Top cover

1. Take out the front cover index screw(9151)disposed on the front frame.
2. Pull out the rewinding knob(3355 set) so as to open the back cover and insert the fulcrum point of a pincette into a slot in the rewinding shaft(3354) so as to unscrew and take out the rewinding knob(3355 set).
3. Take out the rewinding seat(3353).
4. Take out the winding lever cap(3171) and take off the winding lever spring(3158), the washer(W-28) and the winding lever(3155 set).
5. Loosen and take out one setscrew(B31-1.7×2.5) of the speed dial so as to take out the speed dial scale plate(2151), the sensitive plate sheet(2153), the sensitive plate spring(2005) and the speed dial ring(2155).
6. Loosen and take out three screws (B21-1.7×3) so as to pull out the top cover(1004) from the camera body.

Caution : The shutter button(3153) and the coupling washer(3159) in the camera body are apt to be taken off so that care should be taken not to loose them.

B. Dismounting of Bottom cover

1. Loosen and take out two setscrews(B31-1.7×3) and pull out the bottom cover(1005) from the camera body.

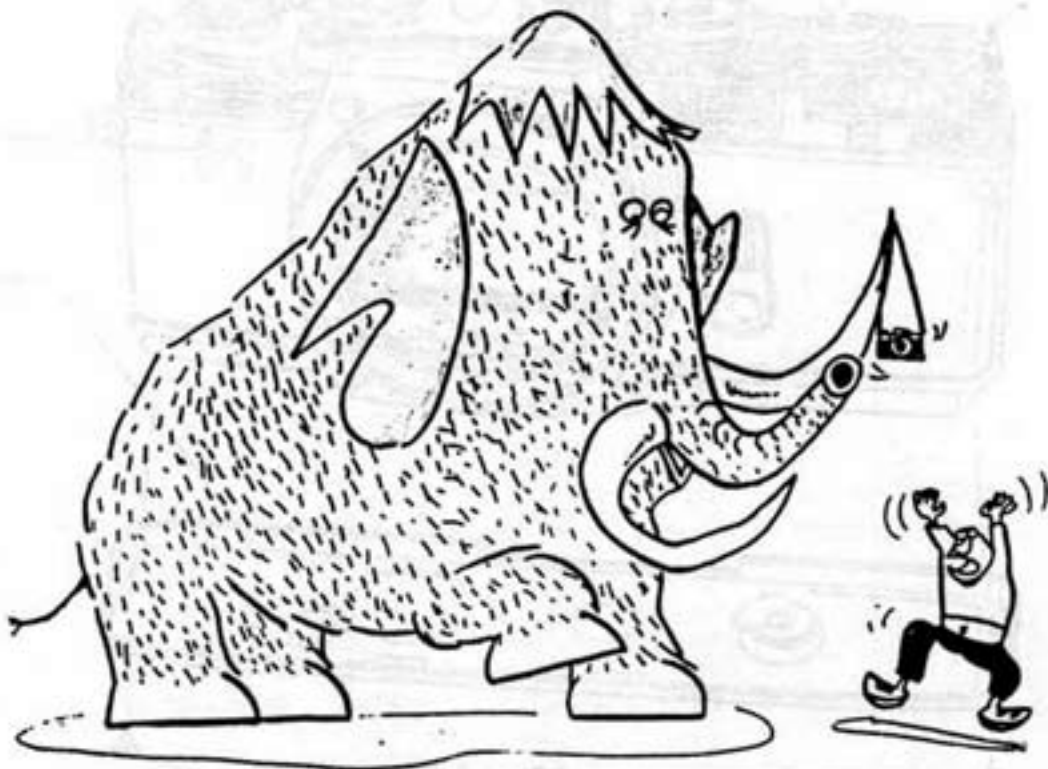

C. Dismounting of View-finder, Meter block

1. Take out the top cover. (See P. 5)
2. Disconnect the soldered portions of the lead wires (white and orange colored) of the wire print plate(4265) of the roof portion of the pentagon prism.
3. Disconnect the soldered portion of the lead wire(black colored) of the wire cord lug plate(4275) from the front part of the camera body.
4. Take out the coupling washer(E-1.2) embedded in the needle following axis(4052) of the needle following lever nut(9451) and the needle following upper lever(4056). Unhook the returning spring(4057) engaged with the rotate axis(4054 set) and pull out the rotate axis(4054 set) and take out the returning spring(4057).
5. Take out two eye-piece frame setscrews(9158) and then the eye-piece frame(5061set).
6. Release the index coupling string(5053) fitted into the slot in the index spring outer tube (5056), and take out the shutter speed index(5057) attached to the index coupling string (5053) from the underneath of the mirror holder. Disengage the slot portion of the index position adjuster(2163) and take out the coupling string(5053). Take out the shutter speed index(5057) from the coupling string(5053).
7. Disengage and take out the AV coupling string(4080) engaged in the slot of the time value pulley(4068). Disengage and locate it at the lateral side of the front frame.
8. Take out three prism holder setscrews(9132) and take off the viewfinder and meter block.

Fig. 2

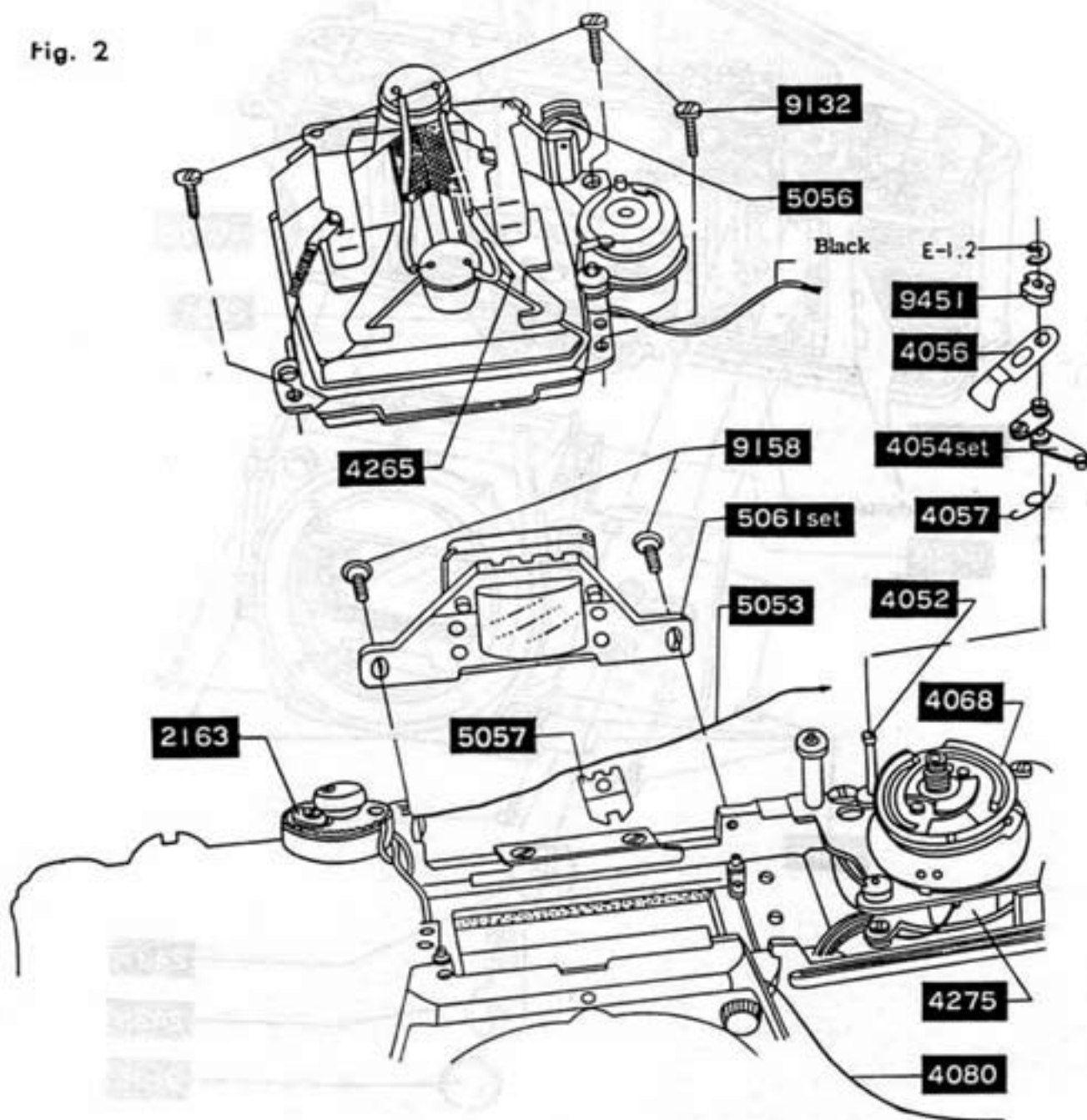

D. Dismounting of Front base frame

1. Dismantle the viewfinder, meter block. (See P. 6)
2. Take out the charge lever setscrew(9106) from the front side of the camera body and the self-timer charge lever(2438) and the self-timer bush(2437).
3. Peel off the front leather-A(1071A) and the front leather-B(1071B).
4. Set the camera body to the state in which the shutter has been released, then take out four base plate setscrews(9148) and one setscrew (B31-2×4) so as to take out the front base frame from the camera body.

Fig. 3

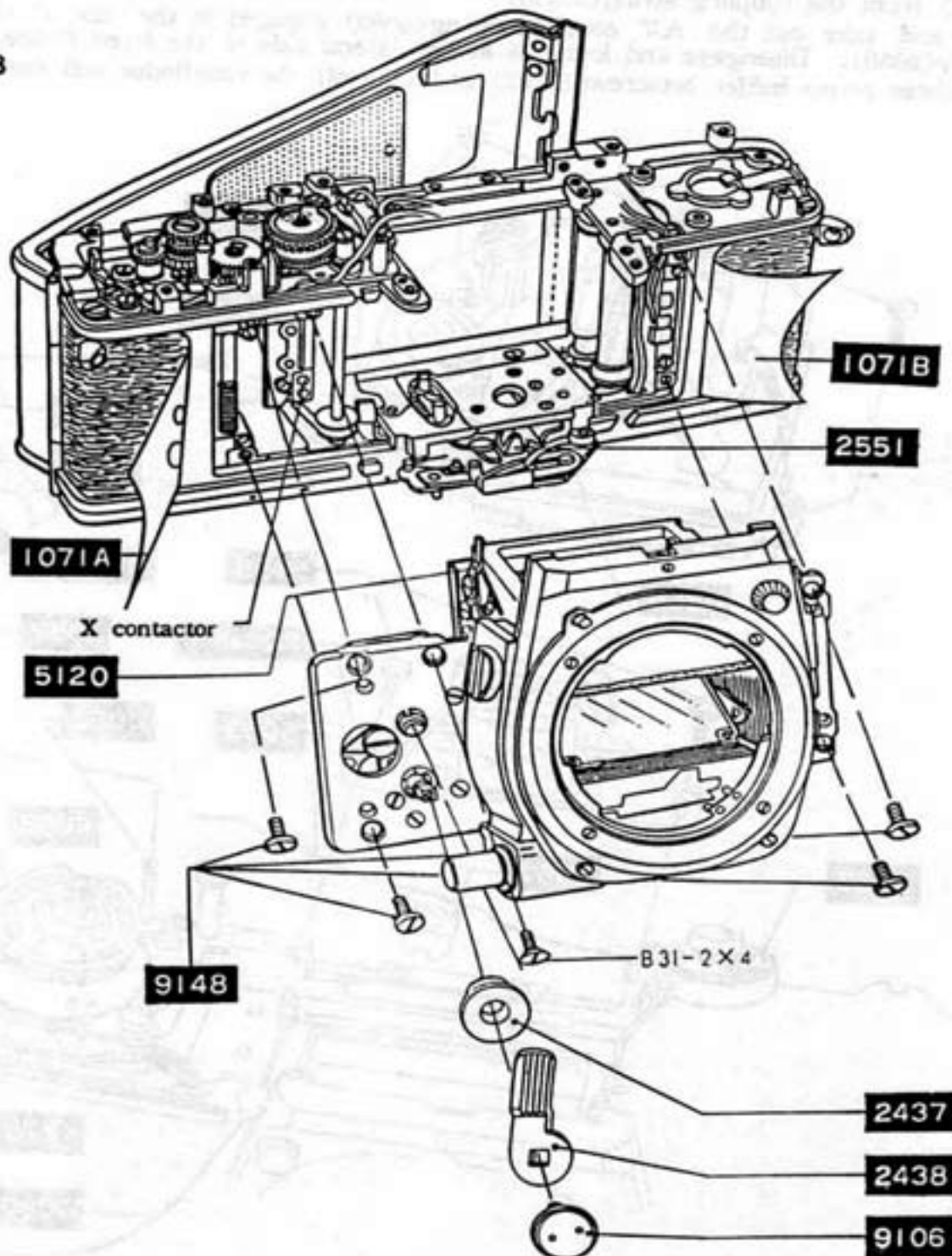

E. Disassembly of View-finder and Meter block

1. Dismantle the viewfinder, meter block. (See P. 6)
2. Disconnect the prism pressure support spring(5072) which is engaged with the prism pressure spring(5069).
3. Loosen and take out the setscrew(B11-1.7×3), and then take out the pressure spring(5069) and the pentagon prism(5803 set).
4. Take out the coupling washer(E-0.8)and then pull out the AV middle pulley-B(4073) and take out the middle pulley-B axis(9154). Loosen and take out one setscrew(B11-1.7×2.5) so as to take out the exposure meter moving coil set(4391).
5. Loosen and take out four setscrews(B31-1.7×2) from the beneath of the condenser holder(5064), and then take out the prism holder(5025 set). Then take out from the condenser holder (5064), the condenser pressure-B(5065), the pressure-F(5067), the condenser lens(5804), the fresnel lens(5805)and the condenser holder(5064).

Fig. 4

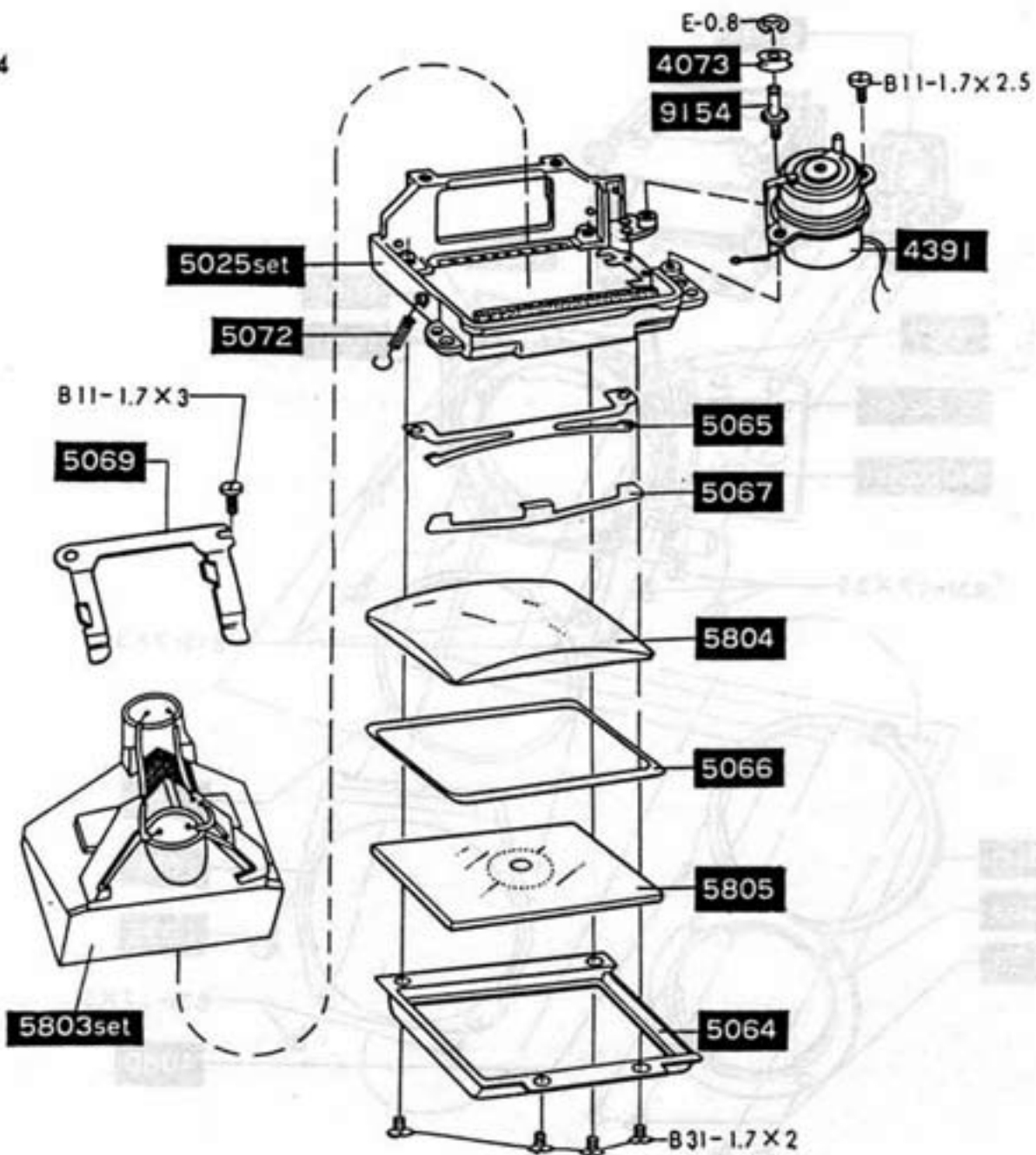

F. Dismounting of Self-timer gear and Mirror box

1. Dismantle the front base frame (See P. 7).
2. Loosen and take out three setscrews (B31-1.7×3.5) so as to take out the self-timer gear (2491).
3. Take out the lock button (1075).
4. Take out four bayonet setscrews (9152) so as to take out the bayonet (1061), and then take out from the slot of the back of the aperture coupling ring (1063), the AV coupling string (4080) so as to take out the coupling ring (1063 set).
5. Take out the coupling ring washer (1064) with care so that the washer may not be deformed, and loosen and take out two setscrews (B73-1.7×3) so as to take out the front cover (1006).
6. Loosen and take out four setscrews (B13-2×3.3) and dismount the mirror box from the front base frame.

Fig. 5

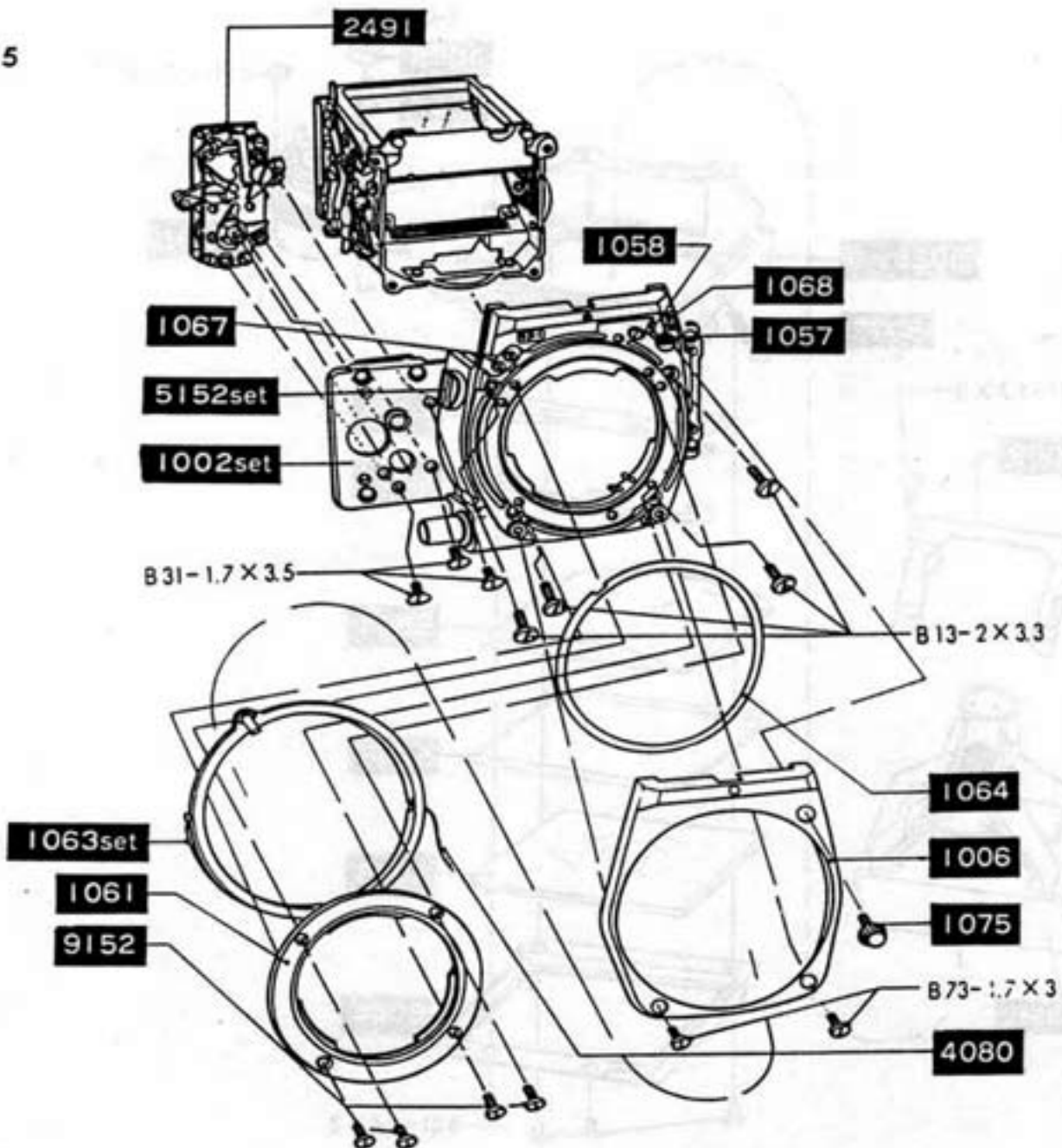

G. Dismounting of Needle following base plate

1. Dismount the top cover (See P. 5).
2. Attach to the rewinding shaft the TV pulley press nut jig (03Y-0013-79) take out the AV coupling string (4080) which is fitted into the slot of the pulley (4068) and disengage the same so as to locate it at the lateral side of the front frame.
3. Take out the TV coupling string (4081) which is fitted into the slot of the adjusting ring (4082) and also disconnect the engagement with the slot of the film speed ring so as to take out the coupling string (4081).
4. Disconnect the soldered portions of the lead wires (yellow, white and blue colored) of the AV safety switch holder (4251) and the lead wires (red and black colored) of the wire cord lug plate (4275) from the front side of the camera body.
5. Loosen and take out one setscrew (B11-1.7×3.3) and also one setscrew (B13-1.4×2) so as to take out the AV safety switch holder (4251 set).
6. Take out the coupling washer (E-1.2) embedded into the needle following axis (4052) and then the following lever nut (9451) so as to take out the following upper lever (4056). Also disconnect the engagement of the following lever return spring (4057) with the rotate axis (4054) and then pull out the rotate axsi (4054 set) so that the return spring (4057) may be taken out.
7. Loosen and take out two setscrews (B31-1.7×3) of the needle following base plate and also three setscrews (B31-1.7×3) from the opening of the base plate so that the needle following base plate.

Fig. 6

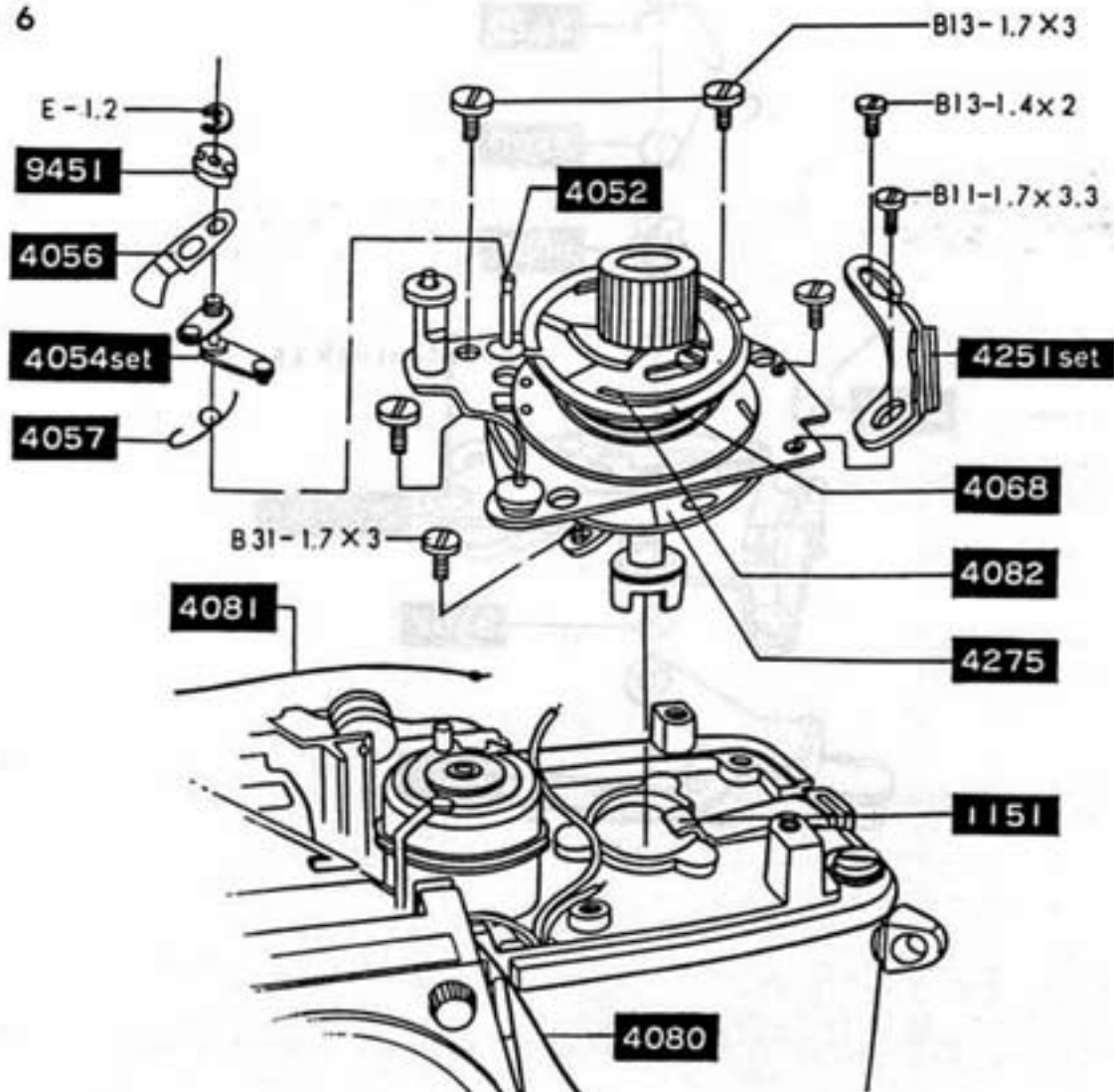

H. Dismounting of Aperture reducing base plate

1. Take out the front base frame. (See P. 7).
2. Attach to the rewinding shaft the rewinding seat(3353) so as to take out the bottom cover. (See P. 5).
3. Expose the bottom of the body and disconnect the charge lever-B spring(3170), rub plate spring(2580), engaged with the charge lever-B axis(9052). Then, take out the axis(9052). Take out the coupling plate spring(2582) and loosen and take out one setscrew(B11-2×3.5) so that the aperture reducing base plate(2571 set) may be taken out of the camera body. When taken out, take out also the charge lever axis receiver(3157) located in the charge lever-B(3169) of the camera body.

Fig. 7

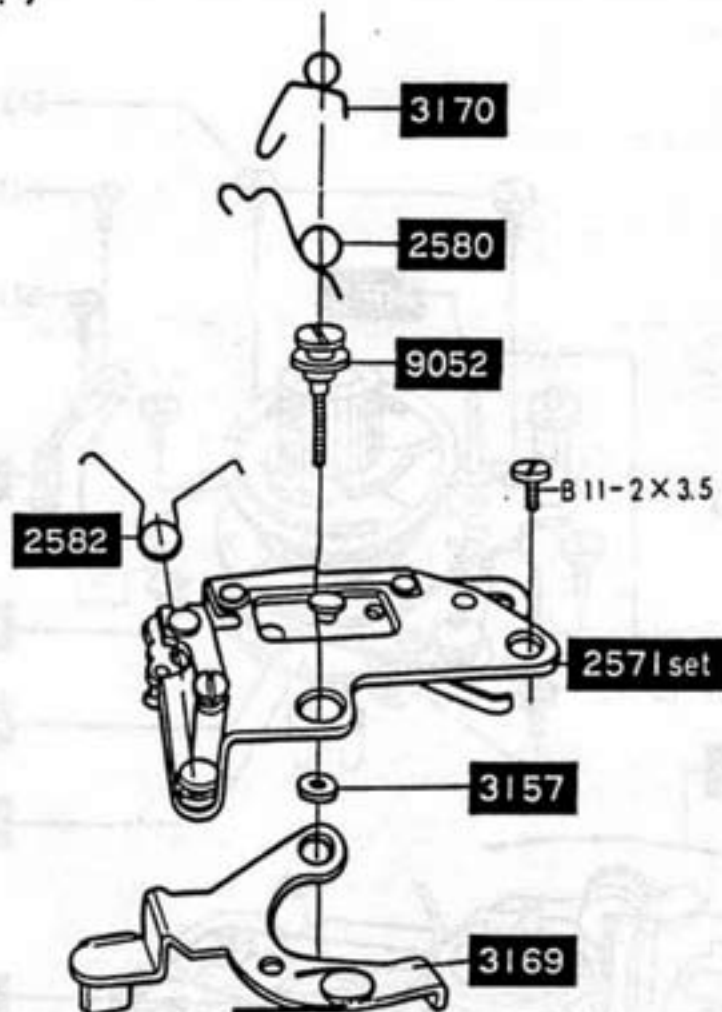

I. Dismounting of Slow-gear and Shutter base plate-A

1. Take out the top cover. (See P. 5).
2. Loosen and take out two setscrews(B13-1.7×2.5) and take out the slow governor(2391).
3. Take out two eye-piece frame setscrews(9158) and the eye-piece frame(5061).
4. Take out the TV coupling string(4081). (Refer to dismounting of needle following base plate. P. 10).
5. Take out the index coupling string(5053). (Refer to dismounting of viewfinder meter block. P. 6).
6. Take outside the lead wires (white and brown colored) placed in the cord holder(2263) and loosen and take out one setscrew(B19-1.7×4.2). Then take out another setscrew(B19-1.7×4.2).
7. Loosen and take out two setscrews (B11-1.7×2.5). Then take out the pulley base(4077 set)and one pulley base axis-B(9156) and also another pulley base axis-A(9153) so that the speed dial stopper(2159), shutter base plate-A(2049 set) may be taken out.

Fig. 8

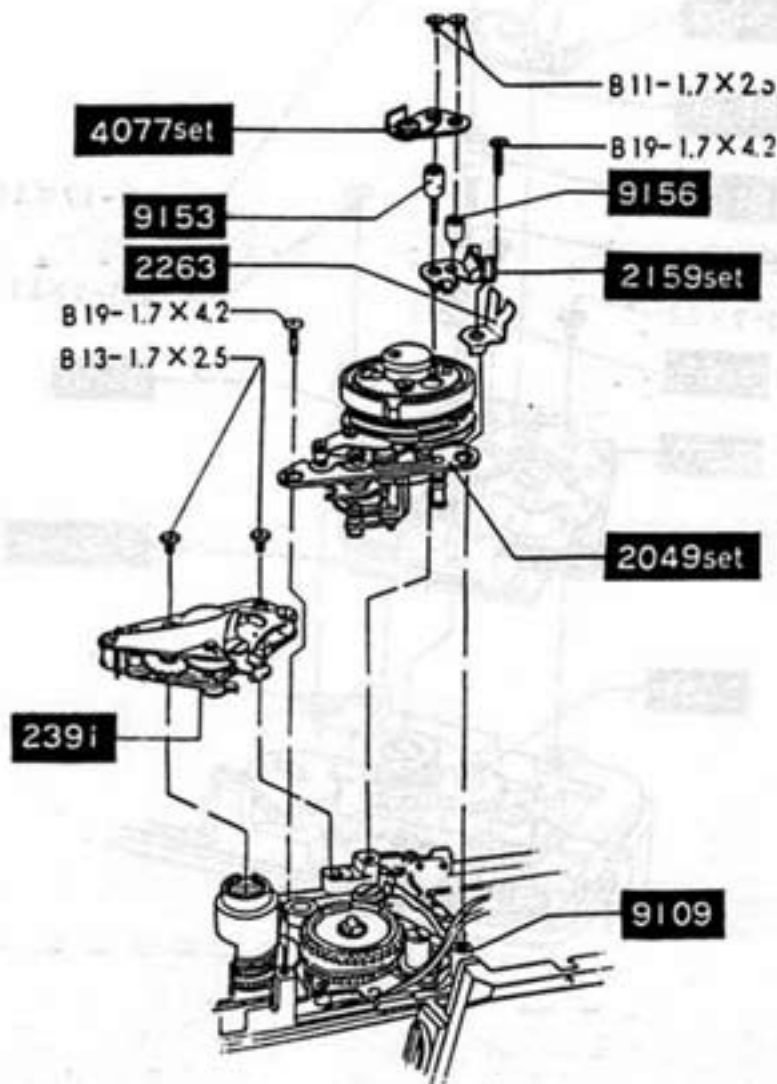

J. Dismounting of Winding base plate

1. Take out the top cover. (See P. 5).
2. Dismount the slow governor. (See P. 12).
3. Take out side the lead wires(white and brown colored) located in the bended portion of the counter dial stopper(5453) and loosen and take out two setscrews(B21-1.7×3.5) so as to take out the stopper unflexing plate(3168) and one dial stopper supporter-A(9107).
4. Loosen and take out two setscrews (B13-1.7×2)so as to take out the idle gear support bearing(3165).
5. Loosen and take out two setscrews(B13-2×3.3) so that the winding base plate may be dismantled from the body.

Fig. 9

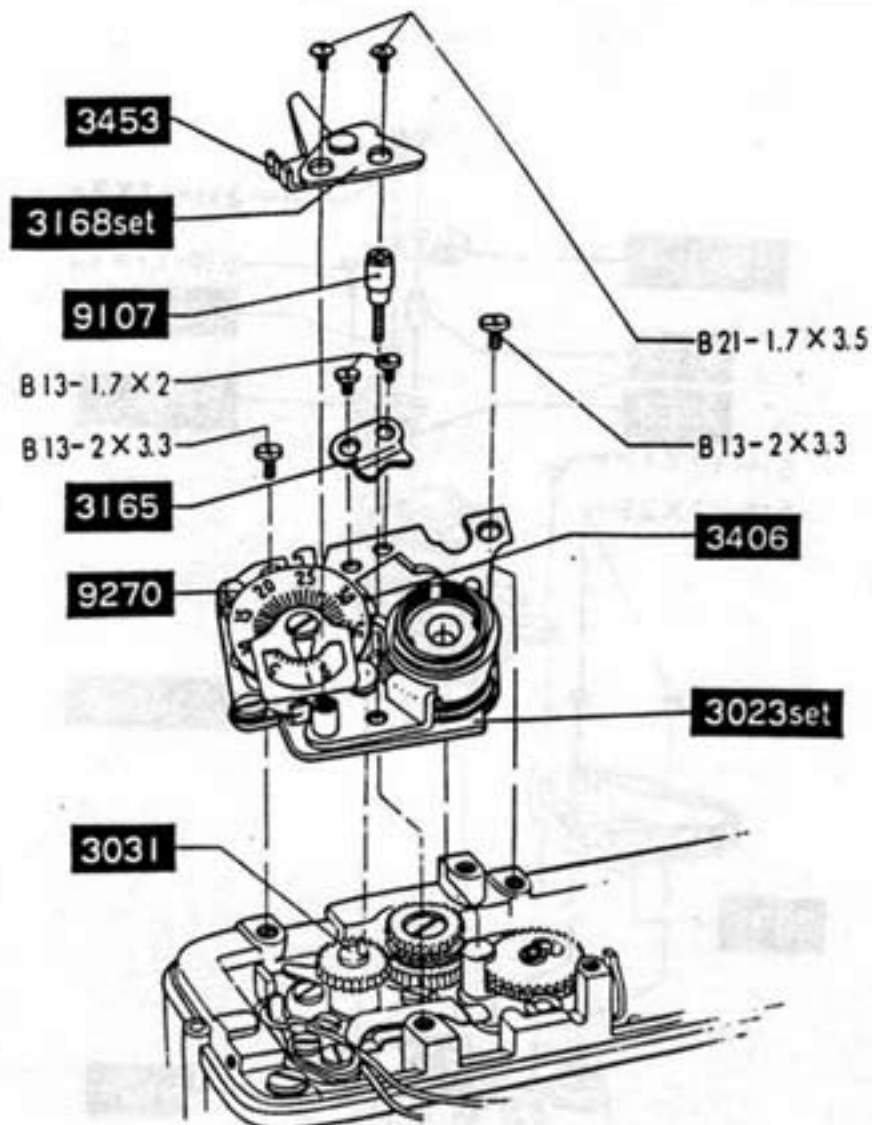
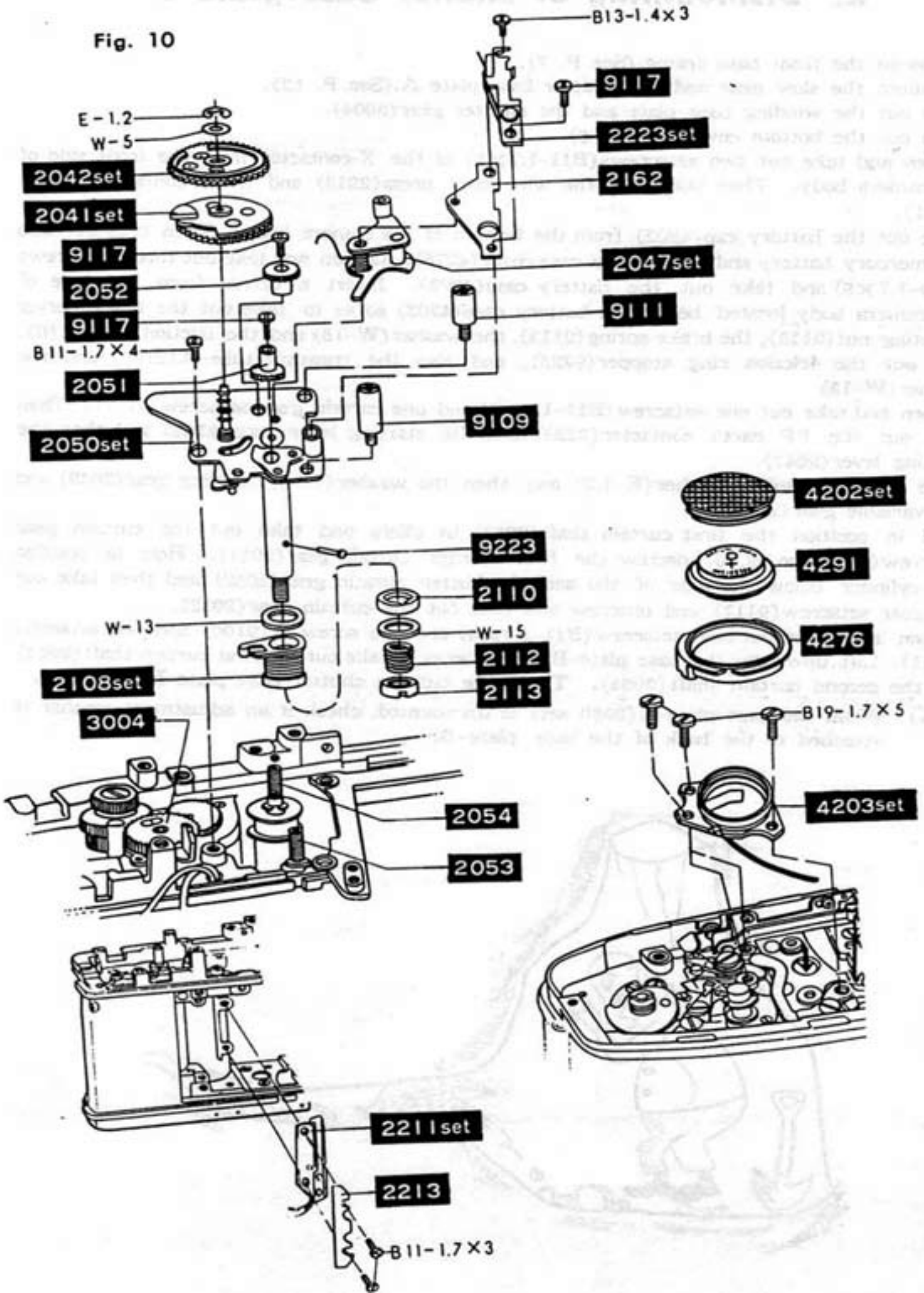

Fig. 10



K. Dismounting of Shutter base plate-B

1. Dismount the front base frame.(See P. 7).
2. Dismount the slow gear and the shutter base plate A.(See P. 12).
3. Take out the winding base plate and the shutter gear(3004).
4. Take out the bottom cover.(See P. 5).
5. Loosen and take out two setscrews(B11-1.7×3) of the X-contactor from the front side of the camera body. Then take out the wire cord press(2213) and the X-contactor holder (2211).
6. Take out the battery cap(4202) from the bottom of the camera body. Then take out also the mercury battery and the battery case cover(4276). Loosen and take out three setscrews (B19-1.7×5) and take out the battery case(4203). Insert a driver from the hole of the camera body located below the battery case(4203) so as to take out the brake spring adjusting nut(2113), the brake spring(2112), the washer(W-15) and the friction ring(2110). Pull out the friction ring stopper(9223), and also the transmit tube-A(2108) and the washer(W-13).
7. Loosen and take out one setscrew(B13-1.4×3) and one curtain gear setscrew(9117). Then take out the FP earth contactor(2223) and the starting lever axis(2162) and then the starting lever(2047).
8. Take out the coupling washer(E-1.2) and then the washer(W-5), driving gear(2042) and the variable gear(2041).
9. Hold in position the first curtain shaft(2053) by pliers and take out the curtain gear setscrew(9117) so as to unscrew the first shutter curtain gear(2051). Hold in position the cylinder below the gear of the second shutter curtain gear(2052) and then take out the gear setscrew(9117) and unscrew and take out the curtain gear(2052).
10. Loosen and take out one setscrew(B11-1.7×4) and one screw-A(9109) and one setscrew (9111). Lift upwardly the base plate-B(2050) so as to take out the first curtain shaft (2053) and the second curtain shaft(2054). Then take out the shutter base plate-B(2050 set).

Caution: When the base plate-B(2050 set) is dismounted, check if an adjustment washer is attached to the back of the base plate-B.

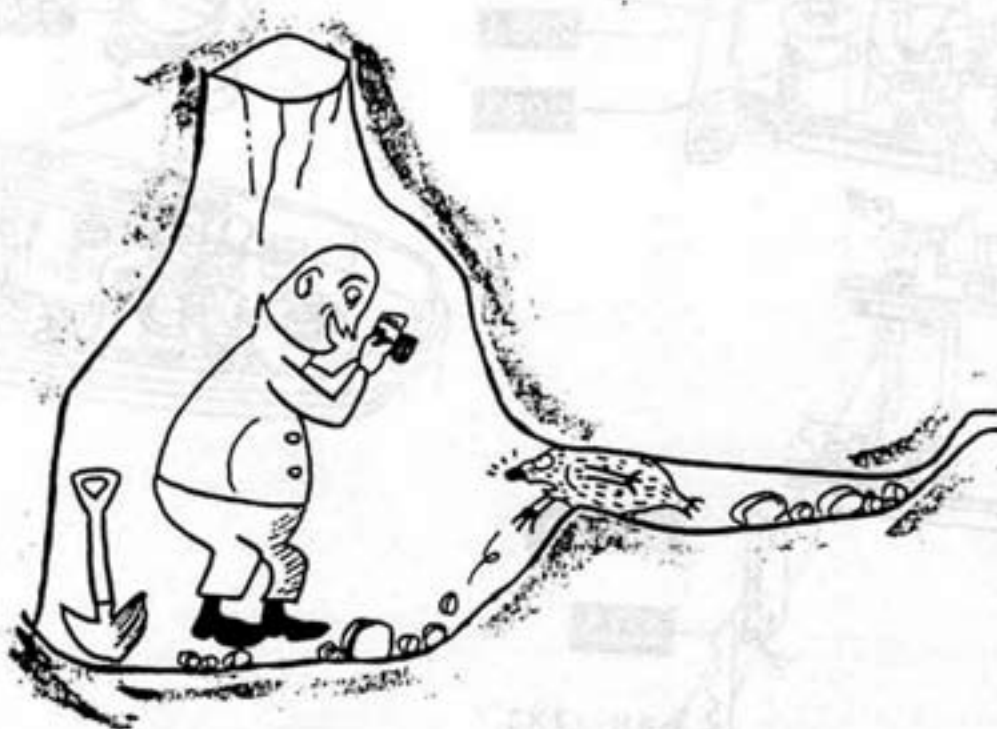

L. Dismounting of Film take-up spool

1. Dismount the slow gear. (See P. 12).
2. Dismount the winding base plate. (See P. 13).
3. Dismount the bottom cover. (See P. 5).
4. Take out the spool shaft nut(9415) from the lower side of the camera body so as to take out the charge cam(3041).
5. Open the back cover and loosen and take out one setscrew(B51-1.7×2.5) for the spool and secure firmly the spool gear(3162) on the camera body. Then turn the spool in the clockwies direction and take out one setscrew(B21-1.7×4.5) from the hole of the spool. Then pull out the film spool shaft(3031) upwardly, and then take out from the camera body the decoration ring(3037), the spring washer(3039) and the film spool(3032).

Fig. 11

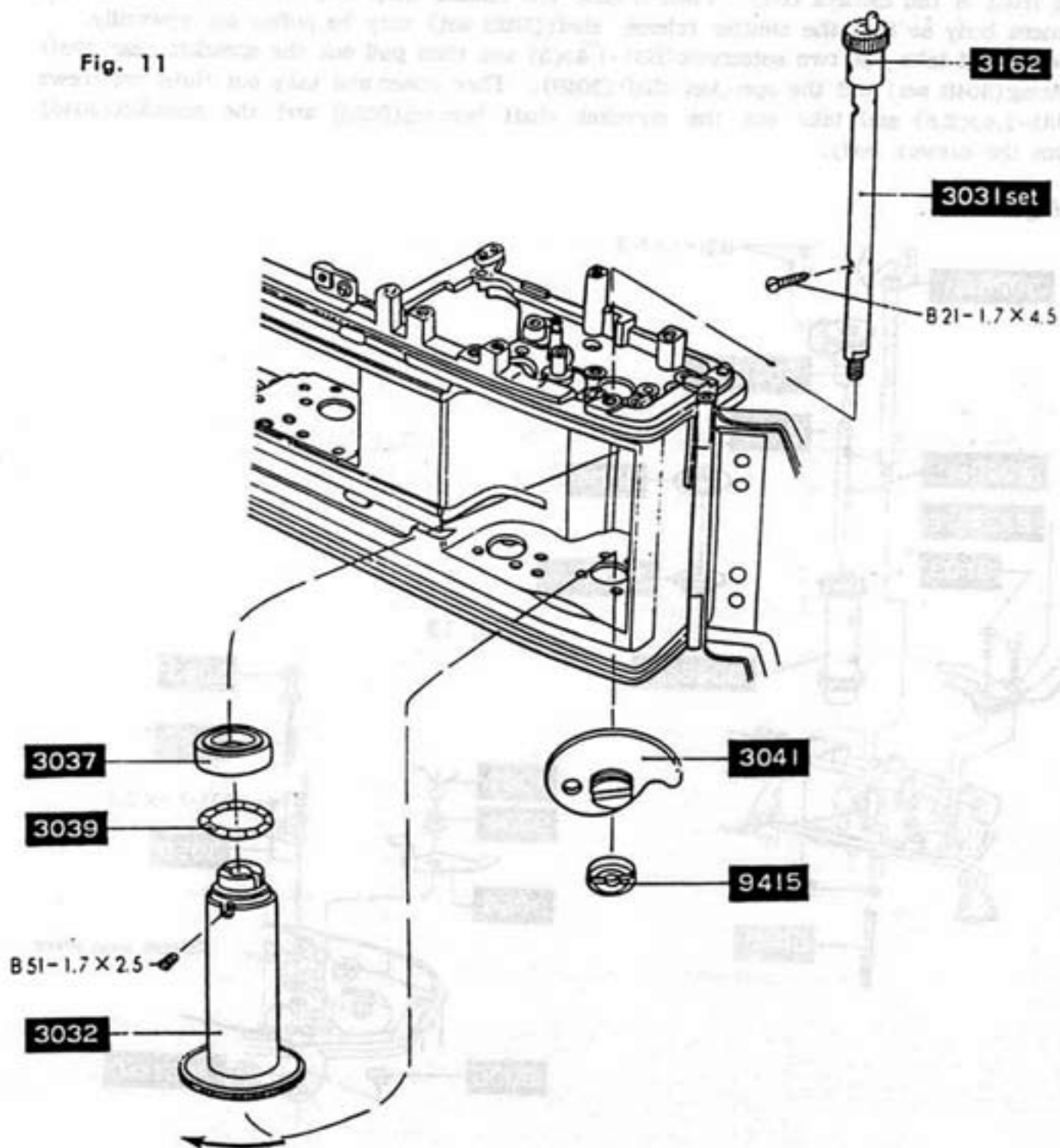

M. Dismounting of Sprocket

1. Dismantle the shutter base plate B. (See P. 15).
2. Take out two setscrews(9103) of the middle contactor base(2224) from the camera body and then the contactor base(2224 set).
3. Take out from the bottom of the camera body the charge lever-A axis(9006) and let the charge lever-A(3061) free toward the outside of the camera body. Then disconnect the sprocket lock lever spring(3067) engaged with the sprocket lock lever(3066) and take out the lock lever axis(9004) and the lock lever(3066).
4. Open the back cover and hold the sprocket when the rewind release button(3053) (left handed screw) is loosened and taken out from the bottom of the camera body. Take out also the sprocket spring(3051).
5. Take out the coupling washer(E-1.5) embedded into the shutter release shaft(3028) from the front of the camera body. Then release the release stop lever of the bottom of the camera body so that the shutter release shaft(3028 set) may be pulled out upwardly.
6. Loosen and take out two setscrews(B31-1.4×3) and then pull out the sprocket gear shaft bearing(3048 set) and the sprocket shaft(3049). Then loosen and take out three setscrews(B31-1.4×2.5) and take out the sprocket shaft bearing(3005 set) and the sprocket(3046) from the camera body.

Fig. 12

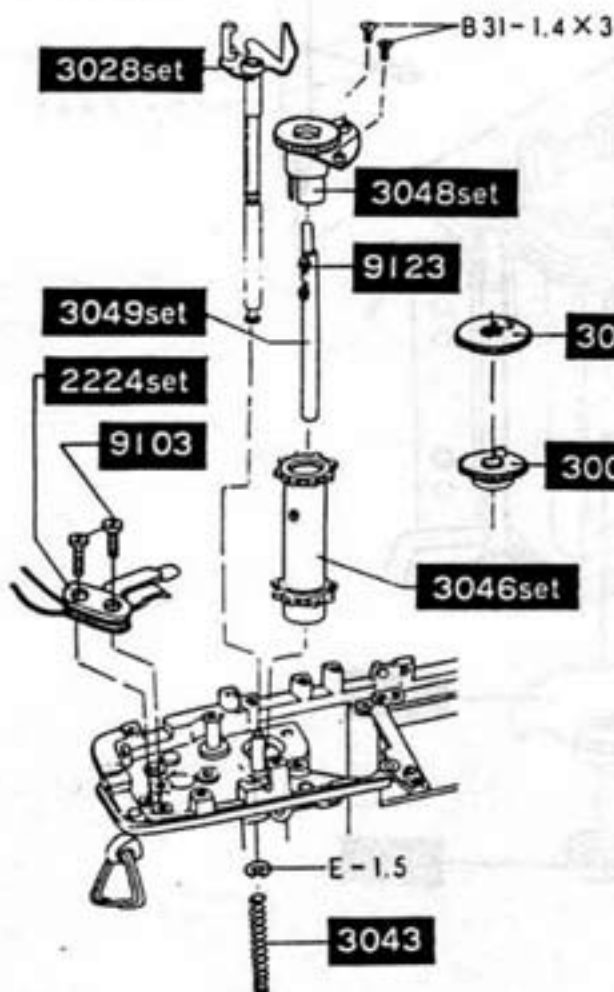
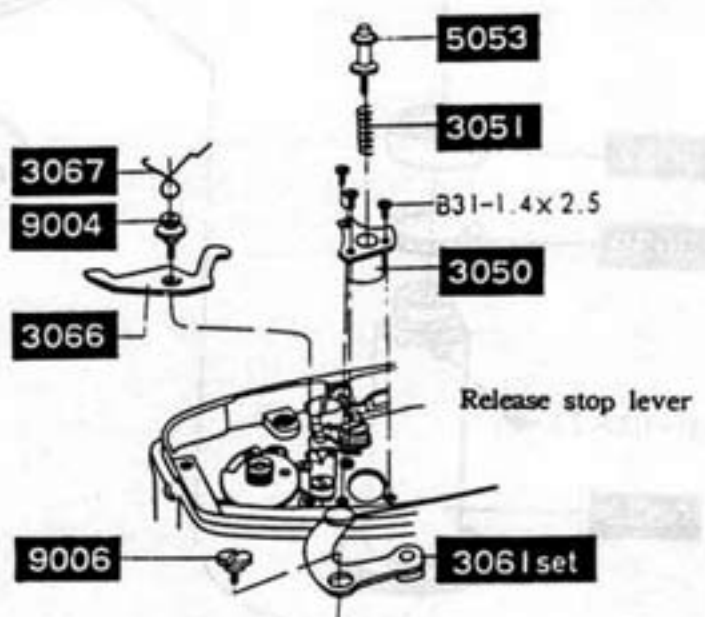

Fig. 13



N. Dismounting of Shutter curtains

1. Dismantle the bottom cover. (See P. 5).
2. Dismantle the front base frame. (See P. 7).
3. Dismantle the shutter base plate-B. (See P. 15).
4. Loosen and take out two setscrews (B11-1.7×1.9, B31-1.4×2.5) from the front side of the camera body and then take out the front light shield plate (1026).
5. Expose the bottom of the camera body and then disconnect the soldered portions of the lead wires (two yellow colored one and red and orange colored, and for the semi-fixing resistor) of the battery switch isolation plate (4271) and the lead wires (black and blue colored, and for the semi-fixing resistor) of the isolation base (4259), then loosen two contactor setscrews (9163) and remove the contactor isolation base (4259 set).
6. Disconnect the reversion spring (2523) engaged with the pre-set lever stopper (2507) and then take out the nail ratchet spring A, B (2074, 2075) from the adjusting nail axis (9205). Unscrew and take out two the curtain spring adjusting nail ratchets (2073) (left handed screw).
7. Loosen and take out two setscrews (B13-1.7×3) and take out the lower plate (2076). Then pull out the spring shaft for the first and second shutter curtains and then take out the first and second curtains from the front of camera body.

Fig. 14

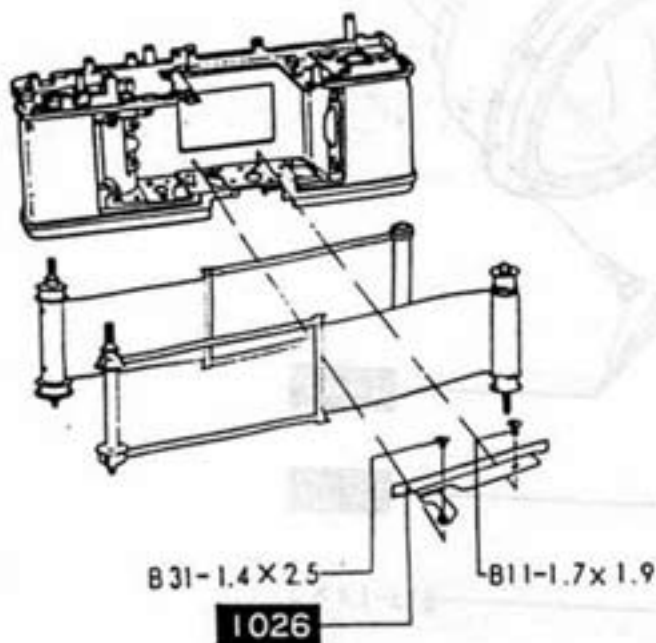
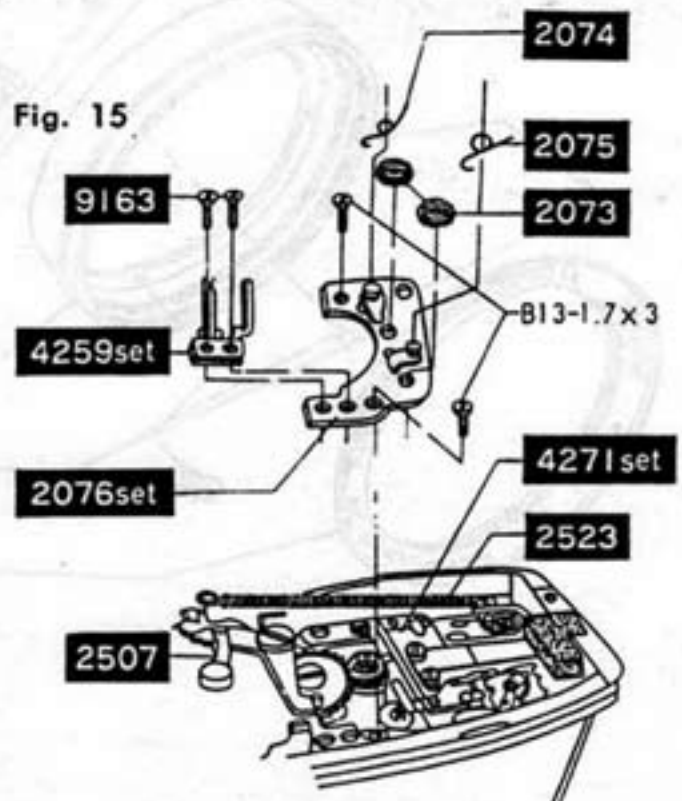

Fig. 15



O. Dismounting of Lens inner barrel

1. Take out the number ring(1241) and loosen and taken out three setscrews (B13-1.4×3) so as to take out the filter ring(1235).
2. Take out four inner barrel setscrews(1403) and take out the inner barrel(1110 set) from the outer barrel.

Fig. 16

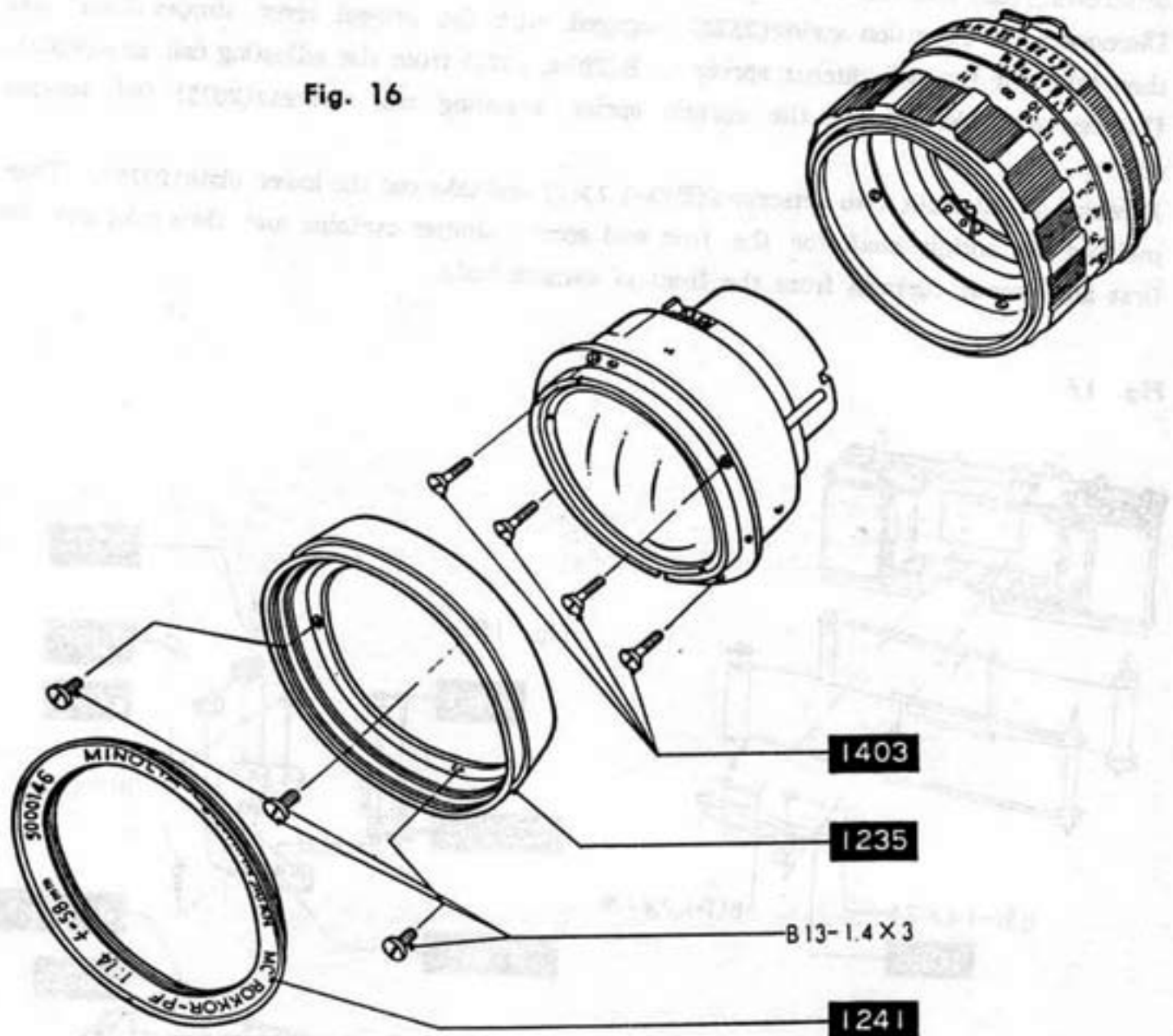

P. Disassembly of Inner barrel

1. Dismount the front and rear lens components from the inner barrel(1110 set).
2. Disconnect the pressure(1424) engaged with the operation plate pin(1407) and loosen and take out three setscrews(B61-1.7×2.2) located around the inner barrel so that the press barrel holder(1115) may be taken out from the inner barrel(1110). Then, take out the diaphragm press barrel(1112), six diaphragm blades(1371 set)and the diaphragm operation plate(1113).
3. Take out the washer(1379) with care so that the washer may be not deformed and then pull out of the inner barrel the cam ring(1111).
4. Disconnect the engagement of the both ends of the aperture spring(1420) and then take out the coupling washer(E-1.9) and the operation lever(1374 set).

Caution: In some cases, an adjusting washer is located below the operation lever(1374 set) so that care should be taken not to lose it.

Fig. 17

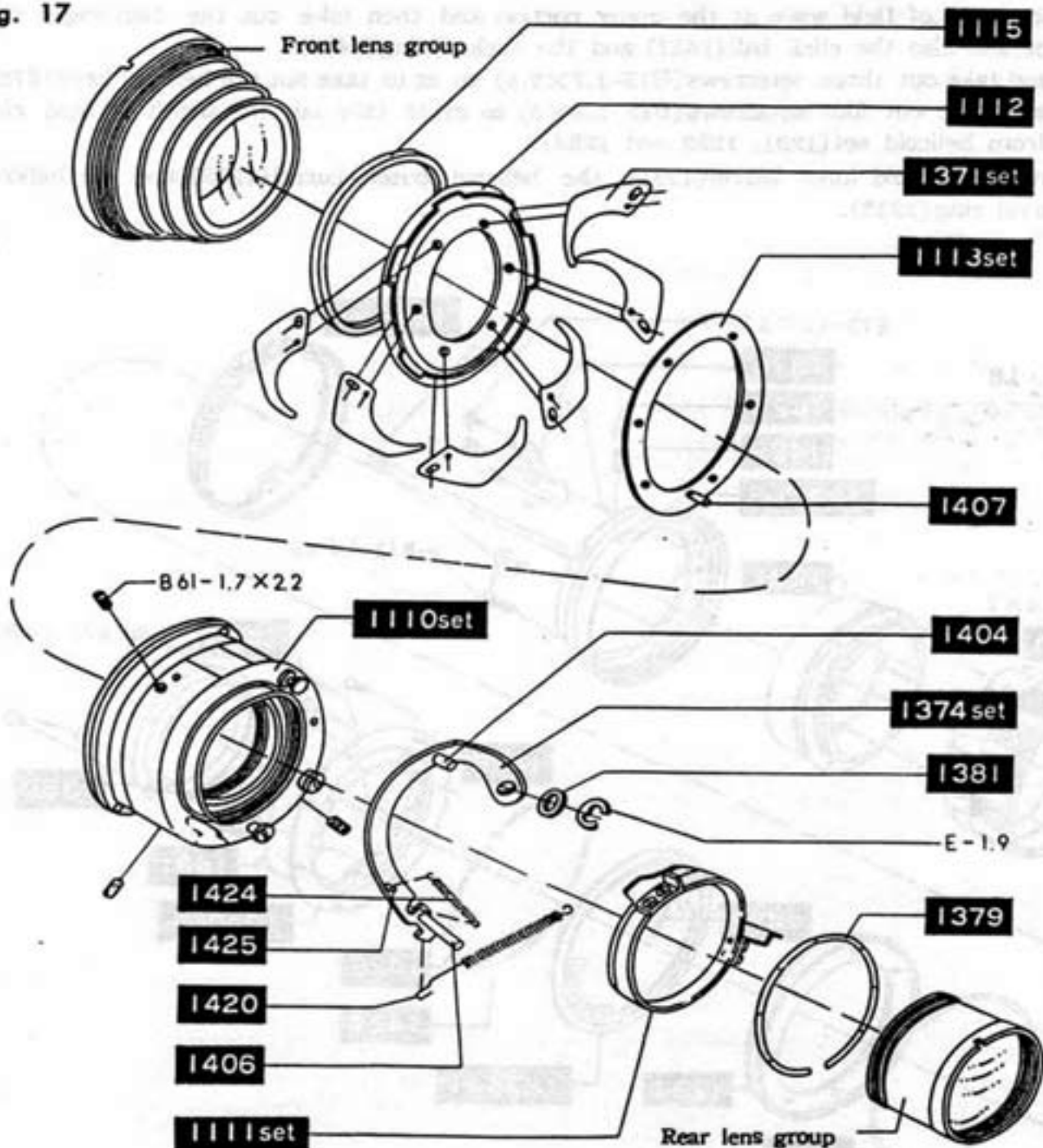

Q. Disassembly of Outer barrel



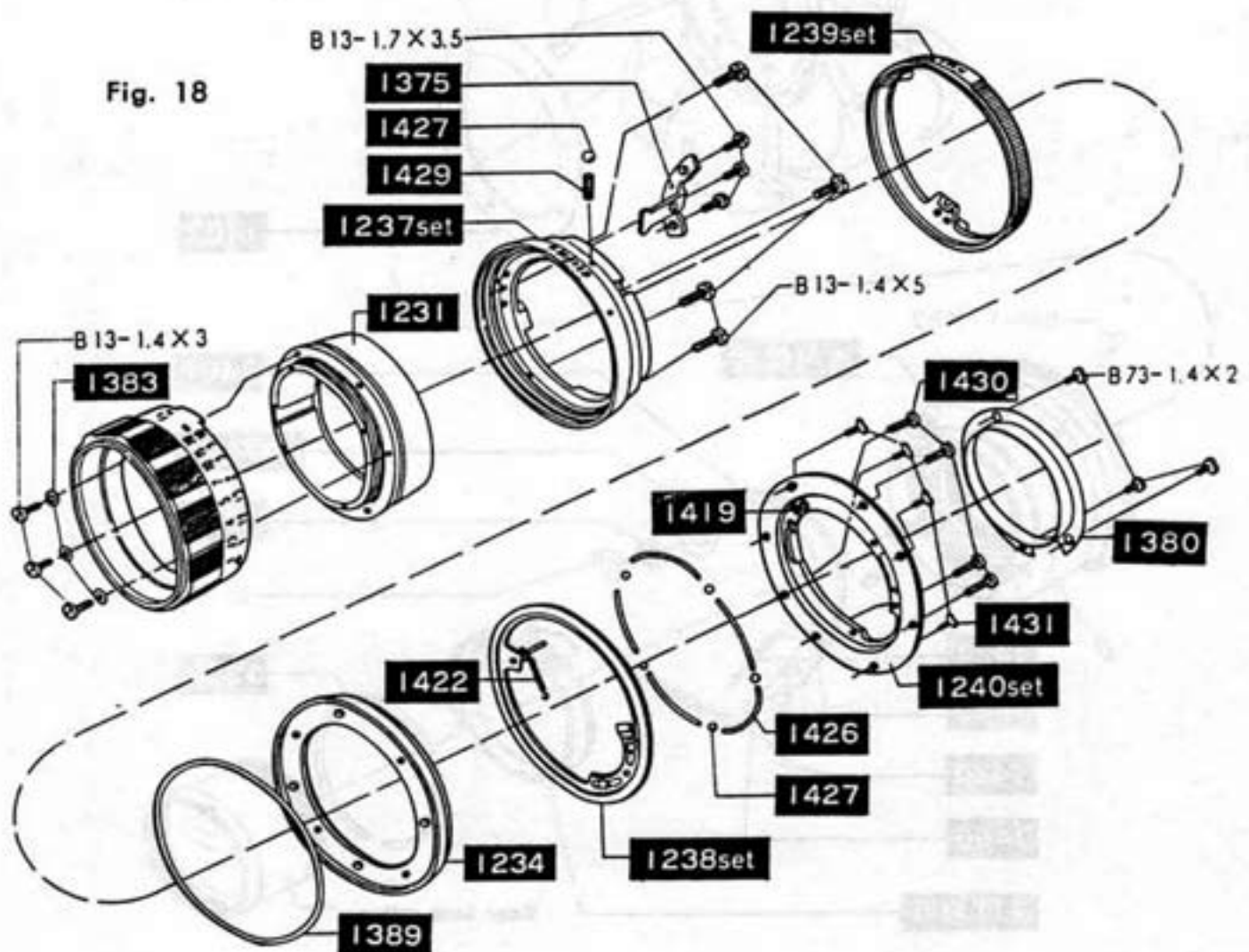



1. Turn the distance scale ring(1236) and set it to the infinity(∞) position. Then, put to mark on the between the distance scale ring(1236) and the helicoid inner barrel(1231).
2. Loosen and take out three setscrews(B13-1.4 \times 3) and then three scale ring set washers (1383)attached to said screws so as to take out the scale ring(1236).
3. Loosen and take out three setscrews(B73-1.4 \times 2) from the rear of the outer barrel so as to take out the bayonet cover(1380).
4. Take out four bayonet setscrews(1430) so as to take out the lens bayonet(1240 set) and also take out the diaphragm ring washer(1389).
5. Disconnect take out the interlock plate return spring(1422) engaged with the return spring hook(1419) from the front side of the bayonet(1240 set).
6. Take out four decoration ring setscrews(1431) from the back of the lens bayonet(1240 set), and also the bayonet(1240), five rotation spacers(1246), five click balls(1427) and the pre-set interlock plate(1238 set).
7. Place the depth of field scale at the upper portion and then take out the diaphragm ring (1239 set)and also the click ball(1427) and the click spring(1429).
8. Loosen and take out three setscrews(B13-1.7 \times 3.5) so as to take out the helicoid key(1375).
9. Loosen and take out four setscrews(B13-1.4 \times 5) so as to take out the depth of field ring (1237) from helicoid set(1231, 1232 and 1233).
10. Take out the helicoid inner barrel(1231), the helicoid outer barrel(1232) and the helicoid outer barrel ring(1233).

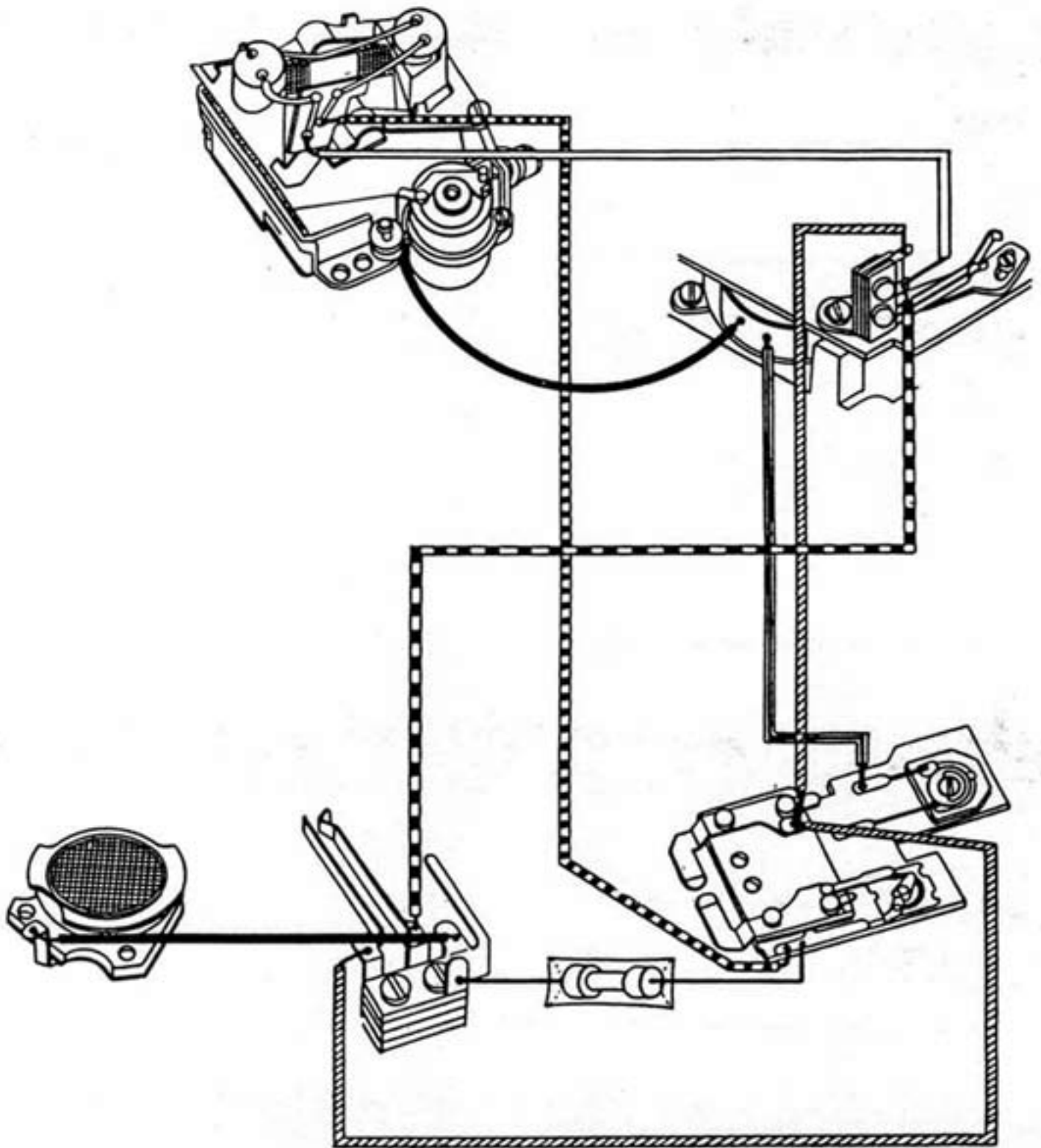

WIRING SCHEMATIC DIAGRAM

Fig. 19



	White or Blue		Blue
	Red		Green or Orange
	Yellow		Black

REASSEMBLY SECTION

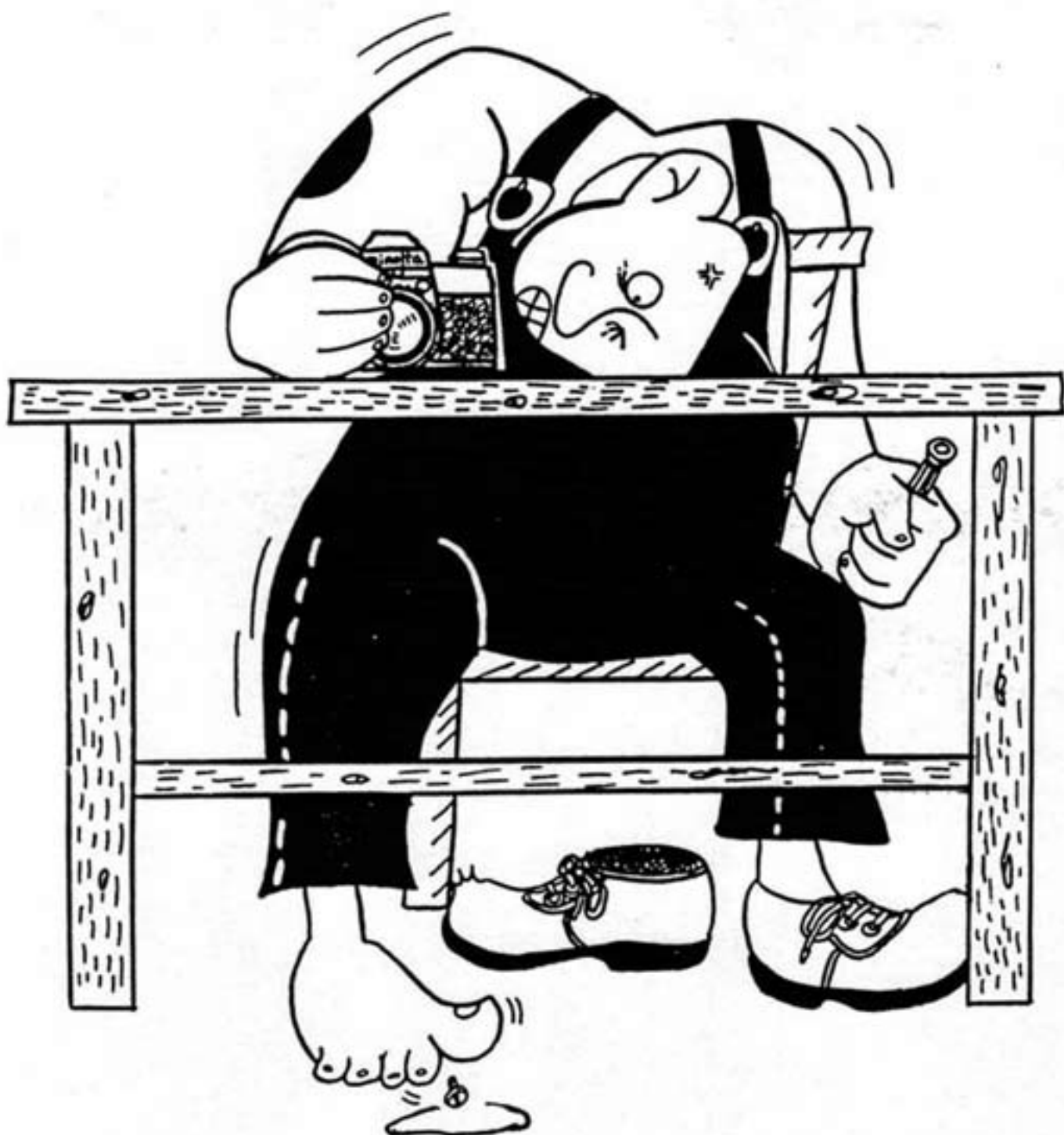

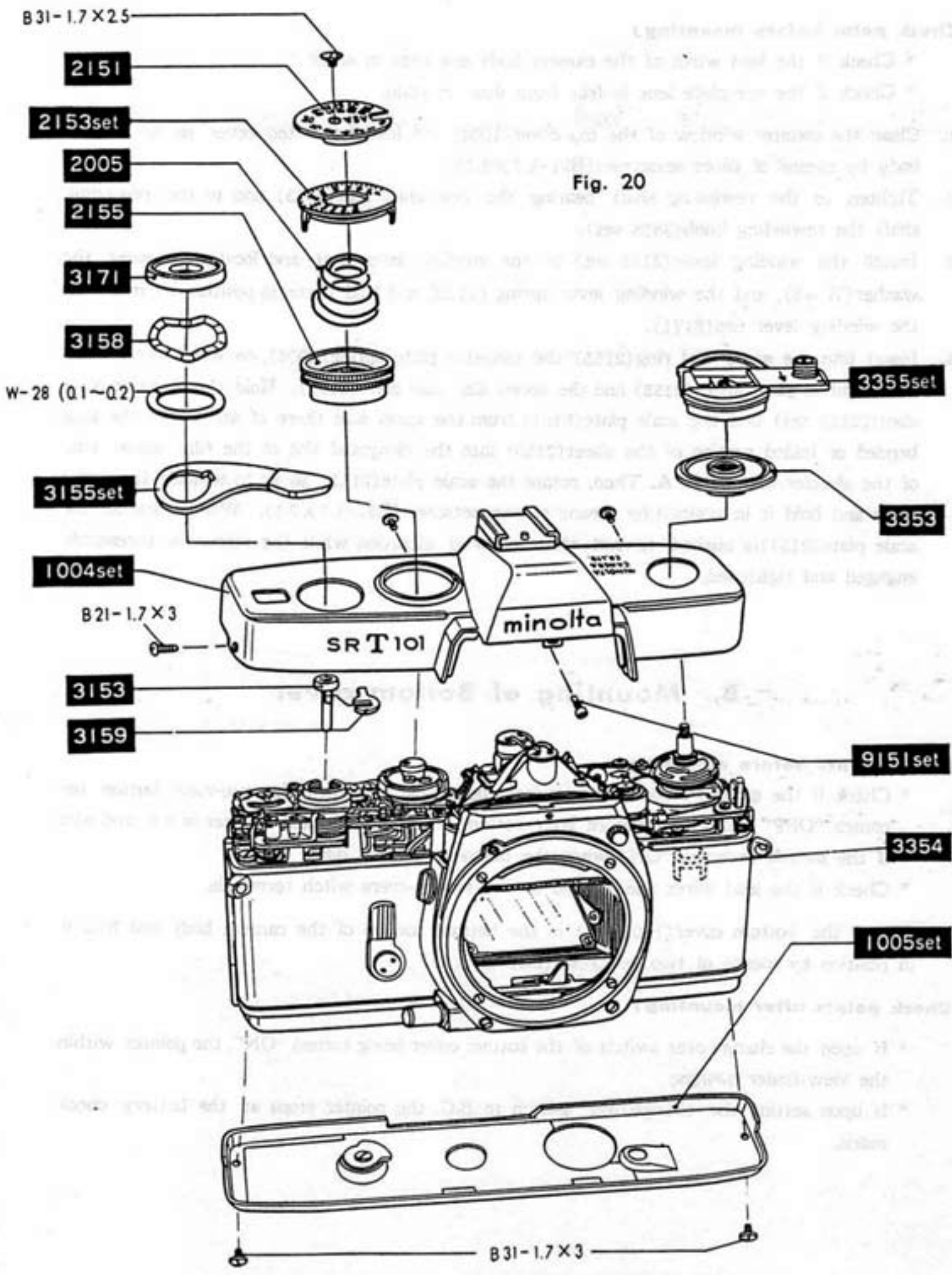

Fig. 20

A. Mounting of Top cover

Check point before mounting ;

- * Check if the lead wires of the camera body are kept in order ;
 - * Check if the eye-piece lens is free from dust or stain.
1. Clean the counter window of the top cover(1004) and install the top cover to the camera body by means of three setscrews(B21-1.7×2.7).
 2. Tighten to the rewinding shaft bearing the rewinding seat(3353) and to the rewinding shaft the rewinding knob(3355 set).
 3. Install the winding lever(3155 set) to the winding lever seat and locate thereover the washer(W-28), and the winding lever spring (3158) and hold them in position by means of the winding lever cap(3171).
 4. Insert into the speed dial ring(2155) the sensitive plate spring(2005), on which are located the sensitive plate sheet(2153) and the speed dial scale plate(2151). Hold the sensitive plate sheet(2153 set) and the scale plate(2151) from the upper side there of and insert the long bended or folded portion of the sheet(2153) into the elongated slot of the film speed ring of the shutter base plate A. Then, rotate the scale plate(2151) so as to coincide the screw holes and hold it in position by means of one setscrew(B31-1.7×2.5). When installed, the scale plate(2151)is pushed toward the clockwise direction while the screw is threadably engaged and tightened.

B. Mounting of Bottom cover

Check points before mounting ;

- * Check if the exposure controlling switch upon pushing down the pre-view button becomes "OFF" when the camera body bottom is exposed and the shutter is set, and also if the switch becomes "ON" when the button is pushed down again.
 - * Check if the lead wires and located on the switch-overs witch terminals.
1. Embed the bottom cover(1005 set) in the bottom portion of the camera body and hold it in position by means of two setscrews(B31-1.7×3).

Check points after mounting ;

- * If upon the change-over switch of the bottom cover being turned "ON", the pointer within the view-finder swings;
- * If upon setting the change-over switch to B.C. the pointer stops at the battery check mark.

Fig. 21

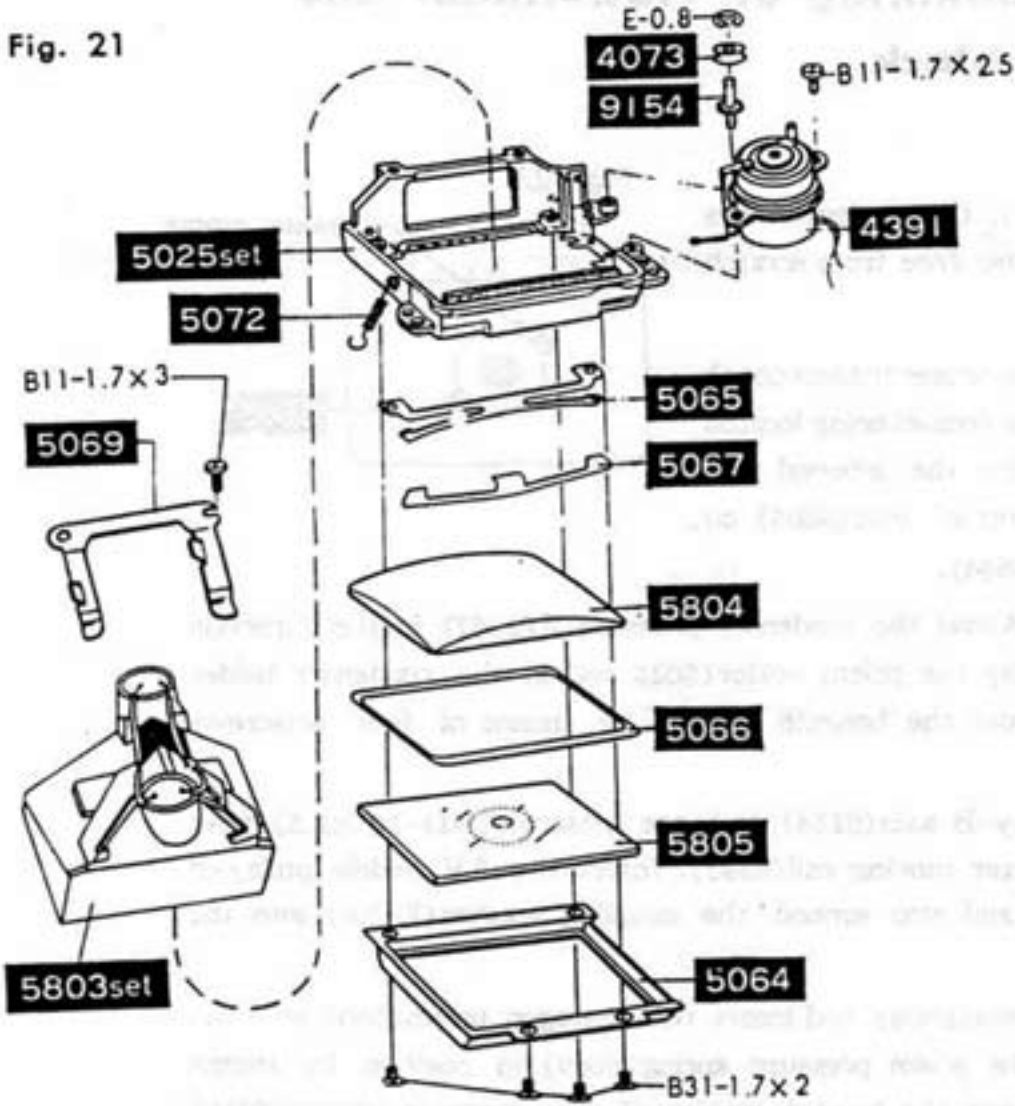
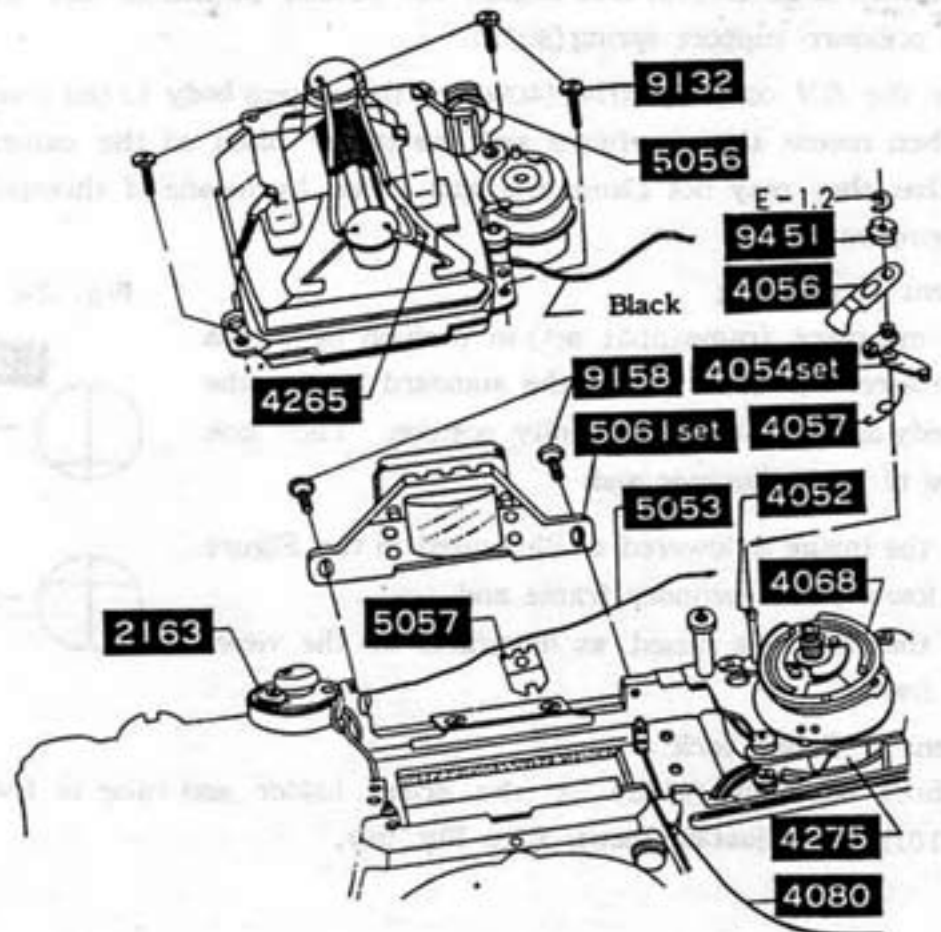

Fig. 22



C. Assembly and mounting of View-finder and Exposure meter block

Check point before assembly ;

- * Check if the pentagon prism(5803), the condenser lens (5804)and the fresnel lens(5805) are free from scratch and stain or dust.

1. Fit the fresnel lens(5805) into the condenser holder(5064) with the portion having on groove of the fresnel being located downwardly and then overlay thereon the interval seat (5066). Clean the surface of the fresnel lens(5805) on which is placed the condenser lens(5804).
2. Insert the condenser pressure-B(5065)and the condenser pressure-F(5067) in the direction shown in the Figure, and then overlay the prism holder(5025 set)on the condenser holder (5064), which is held in position from the beneath thereof by means of four setscrews (B31-1.7×2).
3. Mount by means of one middle pulley-B axis(9154) and one setscrew(B11-1.7×2.5) with care for the meter needle of the meter moving coil(4391). Insert the AV middle pulley-B (4073)into the pulley-B axis(9154) and also embed the coupling washer(E-0.8) into the pulley-B axis.
4. Clean the surface of the condenser lens(5804) and insert the pentagon prism(5803 set) into the prism holder(5025 set). Hold the prism pressure spring(5069) in position by means of one setscrew(B11-1.7×3) and engage the bended portion of the pressure spring(5069) with the pressure support spring(5072).
5. Withdraw the AV coupling string(4080) of the camera body to the front side of the camera body. Then mount the viewfinder and the meter block on the camera body, in such a manner that they may not clamp the lead wires, by means of threepism holder setscrews (9132) temporarily.

6. Adjustment of parallax;

Hold the eye-piece frame(5061 set) in position by means of two setscrews(9158). Mount the standard lens to the camera body and set it to the infinity position. Then look the image of the collimator and:

- * When the image is lowered as illustrated in the Figure right, lower the viewfinder frame and;
- * When the image is raised as illustrated in the view-finder frame.

7. Adjustment of finder back:

Loosen three setscrews(9132) for the prism holder and raise or lower three adjustment screws(9101) for adjusting focus. (See Fig. 25).

Fig. 23

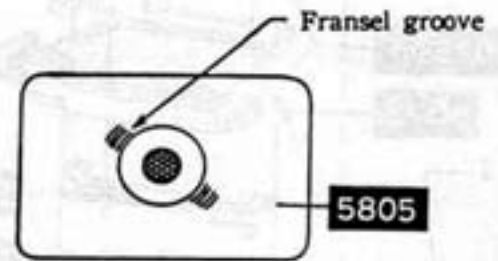
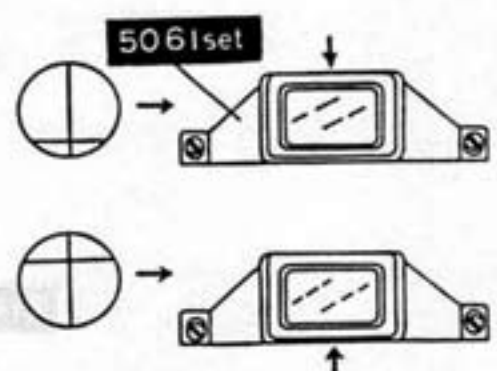
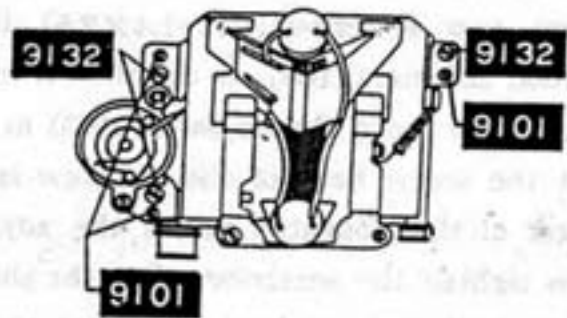

Fig. 24



When the adjustment is to be made from the beginning, turn the adjustment screws about three turns to raise them from their initial positions where the adjustment screws have been screwed first. Then, start adjustment from such raised positions. When adjustment is made, care should be taken not to disconnect the lead wires or give damage to the meter since the yare located adjacent the adjustment screws. When the following adjustment from a) to d) is made and when you look the image, care must be taken to lightly press or hold the pinchers portion. Then, tighten three setscrews(9132) and check again if the image is in focus at such tightened position.

Fig. 25



- a) When the left portion is of a wave form as illustrated in the right figure, the left side is insufficient so that the focus adjusting screw on the left must be lowered for adjustment.
- b) When the left portion is of crossing waves form, the left side is over or in excess so that the left side focus adjusting screw must be raised for adjustment. Conversely when the right side is of a wave form or crossing waves form, the right side is insufficient or excess respectively, so that the right side focus adjusting screw must be adjusted accordingly.
- c) When the lower portion is of a wave form as shown in the right figure, the lower side is insufficient so that the lower focus adjusting screw must be lowered for adjustment.
- d) When the lower portion is of crossing waves form, the lower side portion is in excess so that the lower side focus adjusting screw must be raised for adjustment. Conversely when the upper portion is of a wave form or crossing waves form, the upper side is insufficient or in excess respectively so that the right and left side focus adjusting screws must be adjusted.

Fig. 26

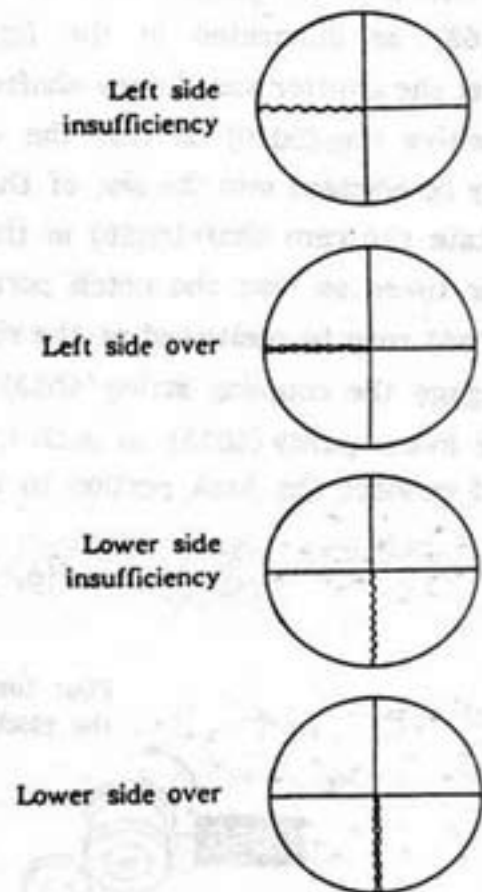

8. Connect to the wire cord lug plate(4275) below the following pointer base plate the lead wire (black colored) from the front side of the camera body by soldering. Pull out from below the pressure spring (5069) and connect the lead wires (white and orange colored) to the wire printed plate(4265) by soldering as indicated in the figure. Take out two setscrews(9158) and the eye-piece frame(5061 set).

Fig. 27

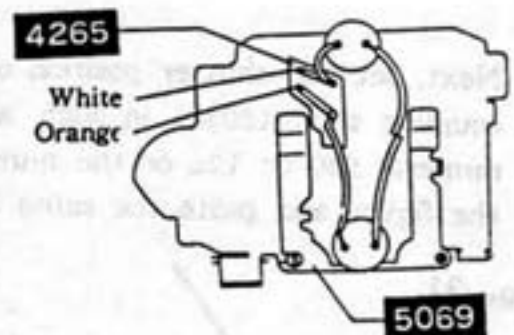

9. Engage the connecting string for a pointer (5053) and loosen two setscrews (B11-1.4×2.5) for the index position adjuster (2163) on the shutter mount base plate -A. Then move the adjuster (2163) in such a manner that the screw head of the setscrew is located at the center of the elongated slot of the adjuster (2163) and then tighten the setscrew. Set the shutter base plate -A to bulb and one knot portion of the index coupling string (5053) is inserted through the hole of the joint gear (2154) on the shutter mount base plate A and pulled out outwardly of the camera body from the beneath of the film sensitive ring (2010) so that the knot portion is engaged with the slot of the adjuster (2163), as illustrated in the figure. Rotate but not twist the shutter speed cam shaft (2156) underneath the sensitive ring (2010) so that the coupling string (5053) may be engaged into the slot of the string pulley (4017). Rotate the cam shaft (5056) in the clockwise direction four times so that the notch portion of the cam shaft (5056) may be positioned at the right overhead position. Engage the coupling string (5053) with two position of the index pulley (5073) in such a manner that the coupling string (5053) may not be twisted and connect the knot portion to the notch portion of the index spring outer tube (5056).

Fig. 28

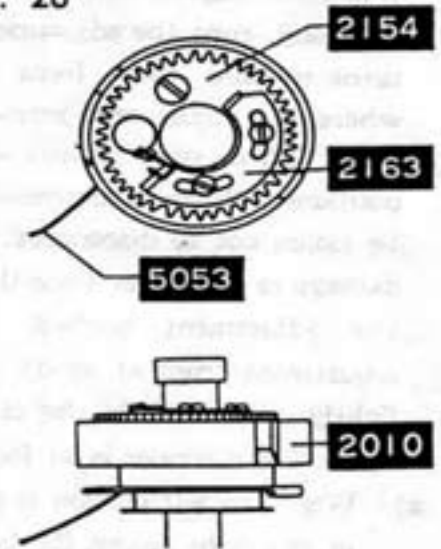

Fig. 29

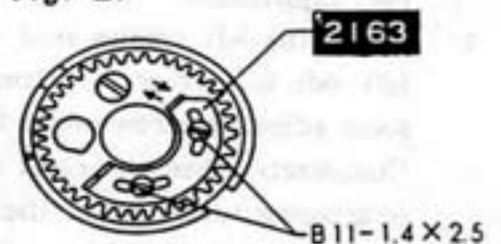
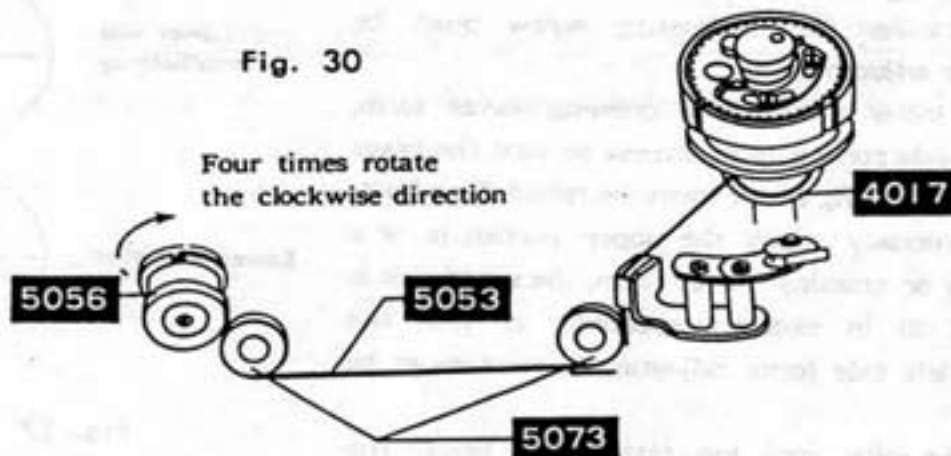
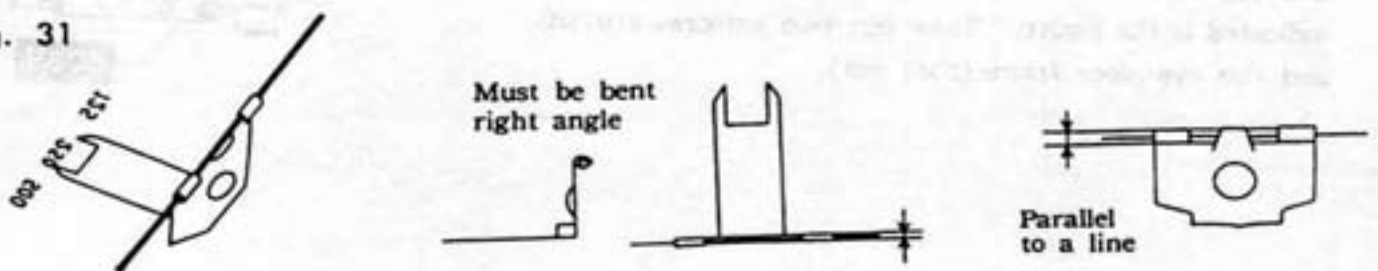

Fig. 30



Next, set the shutter position of the shutter base plate A to 250 or 125 and install the coupling string (5053) in such a manner that the coupling string (5053) may be set to the numeral 250 or 125 or the numeral indicator plate within the view-finder as illustrated in the figure and paste the same in position.

Fig. 31



Look through the view-finder and rotate the joint gear(2154) of the shutter base plate A so as to actuate the shutter speed index(5057) from the numeral plate letters B to 1000 within the view-finder. When the speed index(5057) is actuating in such manner that it swings to the right and left, as illustrated in the figure 32, the speed index(5057) is pressed against and slides on the index adjusting plate(5071) or the prism holder.

Therefore, check the shape and the fixed position of the speed index(5057). Further, when the exposed part of the speed index(5057) varies as illustrated below, the index coupling string(5053) is twisted so that the coupling string(5053) must be released and engaged again correctly. (Fig. 32).

Fig. 32

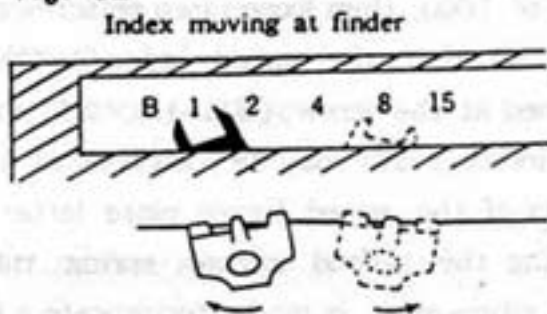
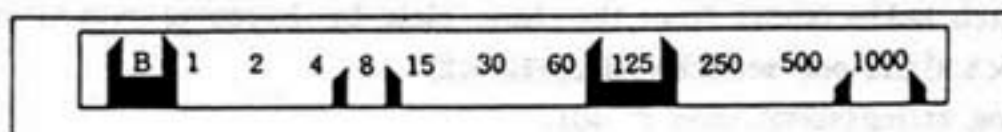

Fig. 33



When the tip end of the speed index(5057) is positioned lower than the numeral plate center within the view-finder, move the speed index(5057) from B to 1000 of the numeral plate. When the speed index(5057) is positioned at the lowest position in the movement from B to 1000, loosen two setscrews(B31-1.7×2.2) so as to push forward the adjusting plate(5071) and adjust and tighten the screws so that the tip end of the speed index(5057) may be positioned at the center of the letters.

Fig. 34



Fig. 35

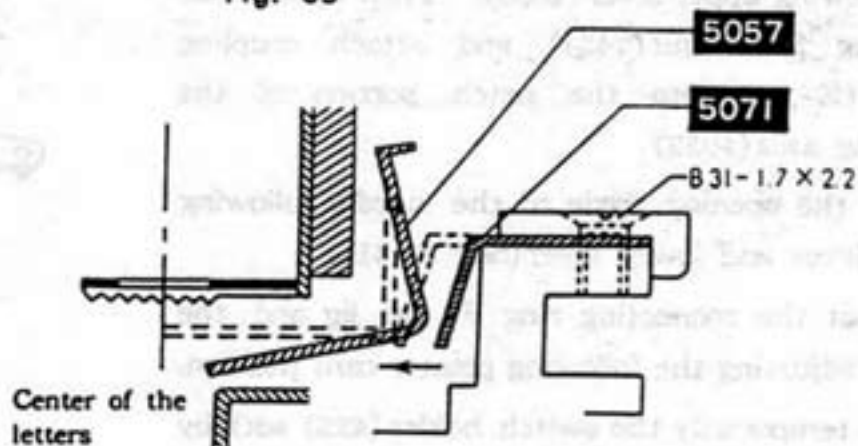

Conversely, when the tip end of the shutter speed index(5057) is overexposed above the letter center of the speed figure plate, release the knot portion of the index coupling string(5053) from the notch or slot portion of the index spring outer tube(5056) and rotate both lateral strings of the speed index(5057) to your side so that they may be made contact with the index adjusting plate(5071), and then attach the outer tube(5056). Finally rotate the joint gear(2154) of the shutter base plate A so as to be set to the shutter

speed of 1000, then loosen two setscrews(B11-1.4 ×2.5) so that the speed index(5057) may be positioned at the screws(B11-1.4×2.5) so that the speed index(5057) may be positioned at the lowest position of the speed figure plate letter 1000 by adjusting the second curtain spring tube(2063). When adjustment is made, reciprocate a few times the speed index(5057) so as to settle the string, and then check the position.

Fig. 36

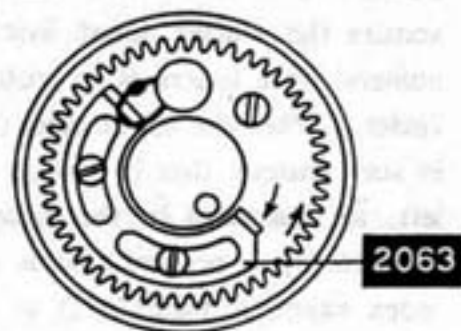

10. Clean the viewfinder glass of the eye-piece frame(5016 set) and attach the same by two frame setscrews(5061 set) and attach the same by two frame setscrews(9158). Then adjust the parallax.(See P. 27).
11. Withdraw the switch holder(4251) from the base plate by loosening and taking out one setscrew(B11-1.7×3.3)and one setscrew (B13-1.4×2).
12. Attach AV coupling string(4080).(See P. 40).
13. Adjust the needle following cam position. (See P. 41).
14. Insert the return spring(4057) with its bended portion being placed upwardly into the needle following axis(4052) of the needle following base plate and insert the rotate axis(4054). Attach the return spring(4057) to the rotate axis(4054 set)as illustrated in the Figure and then insert the following upper lever(4056). Then tighten the following lever nut(9451) and attach coupling washer(E-1.2) into the notch portion of the following axis(4052).
15. Adjust the opening angle of the needle following upper lever and lower lever(See P. 41).
16. Take out the connecting ring F4 set jig and the jig for adjusting the following pointer cam position.
17. Attach temporarily the switch holder(4251 set) by two setscrews(B11-1.7×3.3, B13-1.4×2)and make the adjustment of the AV safety switch contactor. (See P. 42).
18. Check the brightness. (See P. 55).
19. Loosen and take out one setscrew(B31-1.7×2.5) of the speed dial, and then take out the speed dial scale plate(2151), the sensitive plate sheet(2153 set), the sensitive plate spring (2005)and the speed dial ring(2155). Then, attach the top cover. (See P. 25)

Fig. 37

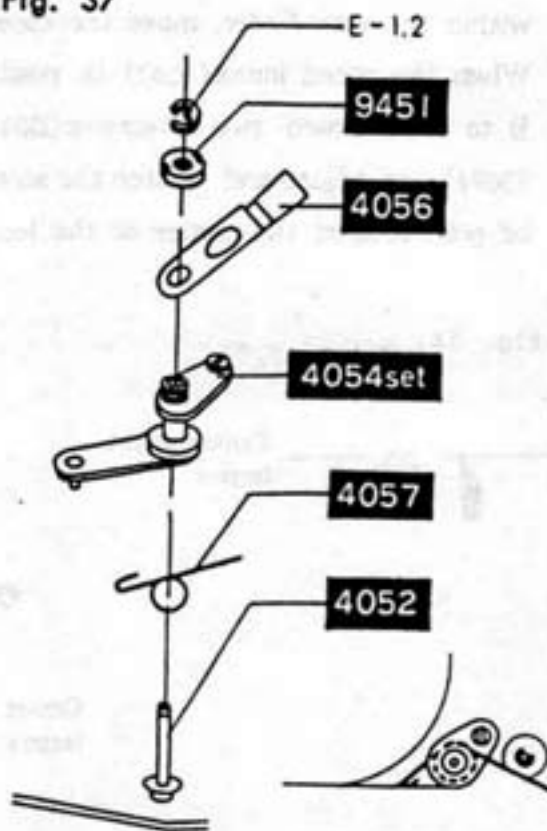

D. Mounting of Self-gear and Mirror box

Check points before mounting :

- Check if the self-timer gear (2491) moves smoothly at its end without stopping in the course or its movement when the self-timer gear (2491) is equipped with the charge lever (2438) and rotated in the direction indicated by the arrow and when the starting plate spring (2431) is pushed down.
 - Check if the mirror is lifted up or cleared when the operation lever-A (5153) of the mirror box is rotated in the direction indicated by the arrow and is engaged with the hook lever plate (5169) and when the hook lever plate is released. Check also if the mirror comes down when the mirror release lever-B (5117) and the mirror lock release lever (5153) are released in the direction indicated by the arrow in the figure.
 - Check if the light shield plate of the mirror box located in front of the mirror box actuates in a correct manner.
 - Check if the contact of the isolator base (2241 set) is in contact with the contact of the synchro terminal (2291) from the back of the front base plate (1002).
1. Attach the front base plate (1002 set) to the self-time gear by three setscrews (B31-1.7×3.5).
 2. Lift up the mirror pushing lever (5119) of the mirror box so as to engage the same with the release lever (5135). Attach the front base plate (1002 set) in such a manner that the mirror lock knob (5152) of the base plate (1002 set) is in the state where the mirror is down and the pin of the mirror lock cam (5133) located inside of the base plate is positioned as indicated in the figure. Then, tighten four setscrews (B13-2×3.3) from the front side of the base plate (1002 set).
 3. Insert the AV coupling string (4080) into the AV middle pulley-A (1068) from the front side of the base plate (1002) so that the coupling string (4080) may be extended by about 3cm. forwardly of the base plate (1002).
 4. Check the engagement of the lock lever spring (1058), and then place the coupling string (4080) at the right side of the lock lever bush (1057). Then, embed the front cover (1006) into the base plate (1002), and thereof so as to exert the force of front cover (1006) to the inside thereof. Then tighten two setscrews (B73-1.7×3).

Fig. 38

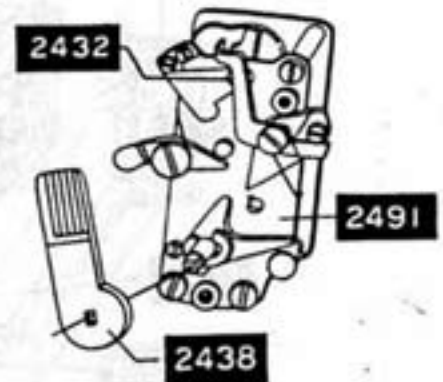

Fig. 39

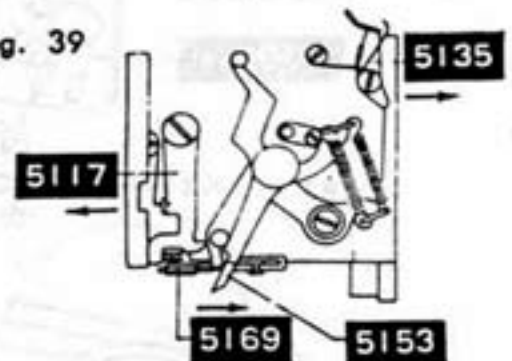

Fig. 40

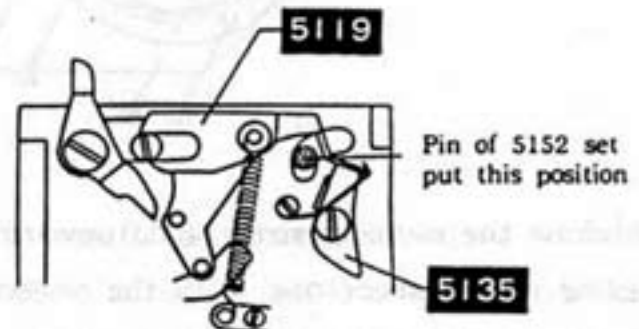
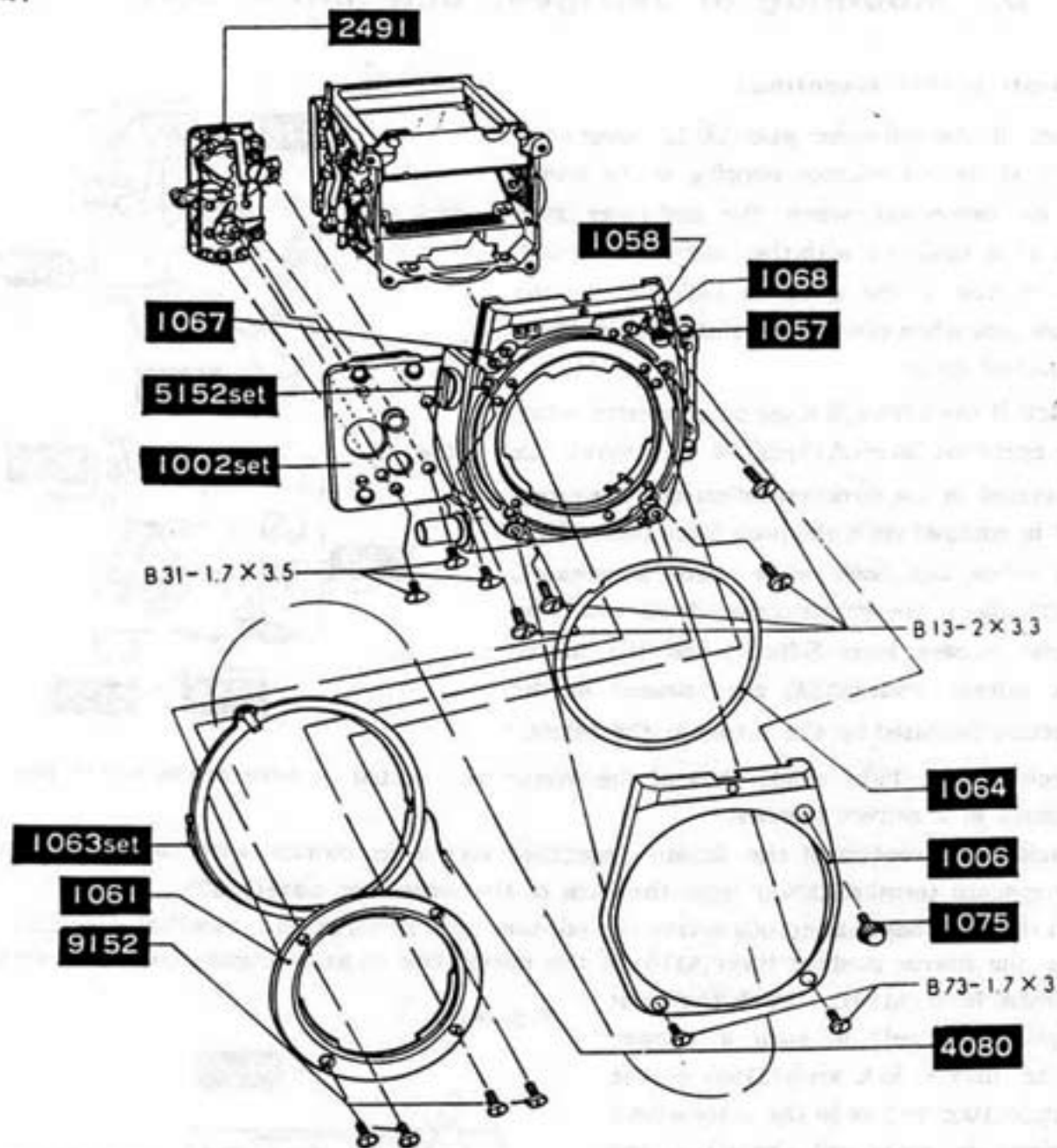
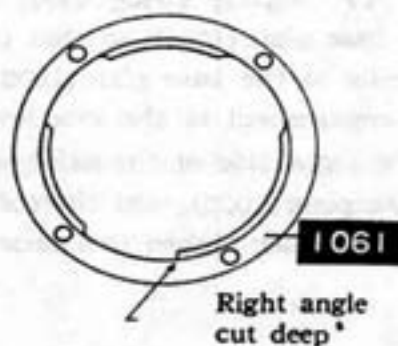

Fig. 41



5. Withdraw the coupling string (4080) upwardly, and then engage the notch portion of the coupling ring washer (1064) with the projection of the coupling ring stopper (1067).
6. Engage the knot portion of the coupling string (4080) into the inside of the slot of the back of the aperture coupling ring (1063), and then paste the same. Then, attach the aperture coupling ring (1063).
7. Mount the bayonet (1061) at such a position as indicated in the figure by four bayonet setscrews (9152).
8. Mount the lock button (1075).

Fig. 42



Check points after mounting :

- Check if the self-gear actuates correctly.
- Check if the coupling string (4080) extending backwardly of the base plate (1002 set) actuates lightly and smoothly when the coupling string (4080) is lightly pulled back so as not to be disengaged from the pulley and when the connecting ring is actuated by means of the connecting ring pin. If the movement of the coupling string (4080) is heavy, the cause is that the washer (1064) is deformed or the front cover (1006) is attached to the wrong position. Check and make suitable countermeasures against such defects.
- Check if the mirror lifts up when the mirror lock is lowered and if the mirror comes down when the mirror lock is returned to its initial position. When and if there is something wrong with the mirror lock, adjustment for the mirror lock must be made according to the following instruction:

Mirror lock adjustment :

Push the operation lever-A (5153) of the mirror box in the direction indicated by the arrow and engage with the hook lever plate (5169). Then release the hook lever plate so as to hold the mirror in a clear position. (See Fig. 43). In this position, check if the clearance between the mirror lock release lever (5153) and the tip end of the mirror lock lever-A (5118) is in the order of 0.5 to 1.5mm when looking down the mirror box from above.

When the mirror lock is out of order, the cause is that the clearance is less than 0.5 mm or the mirror returning lever fails to click in because the mirror lock release lever (5135) touches the mirror box. Disengage the engagement of the returning lever (3154) and the release lever-B (5117) of the mirror box so as to let the mirror come down. Displace slightly the mirror lock knob (5152) from its click in position and make an adjustment for the clearance by bending the bended portion of the release lever (5135) is spaced apart by the maximum distance from the attaching boss for the front frame of the mirror box.

Fig. 43

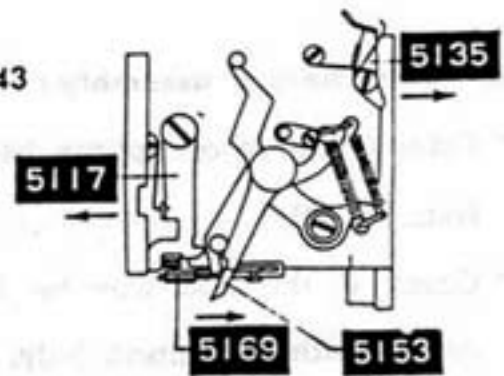

Fig. 44

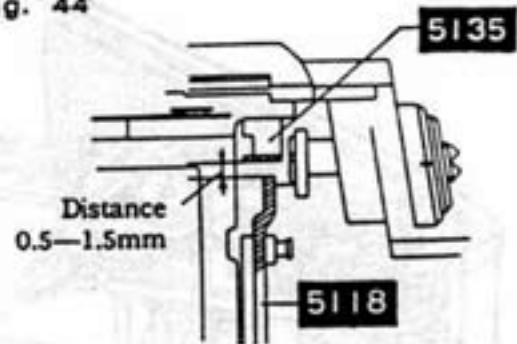
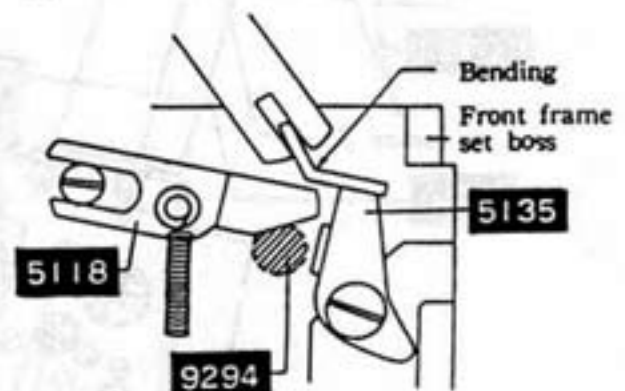

Fig. 45



E. Assembly of Front base frame

Check points before assembly :

- * Refer to the check points before and after mounting of the self-time gear and the box. (P. 32).
- * Check if the lead wire for the X terminals of the camera body is placed along in contact with the camera body.

Fig. 46

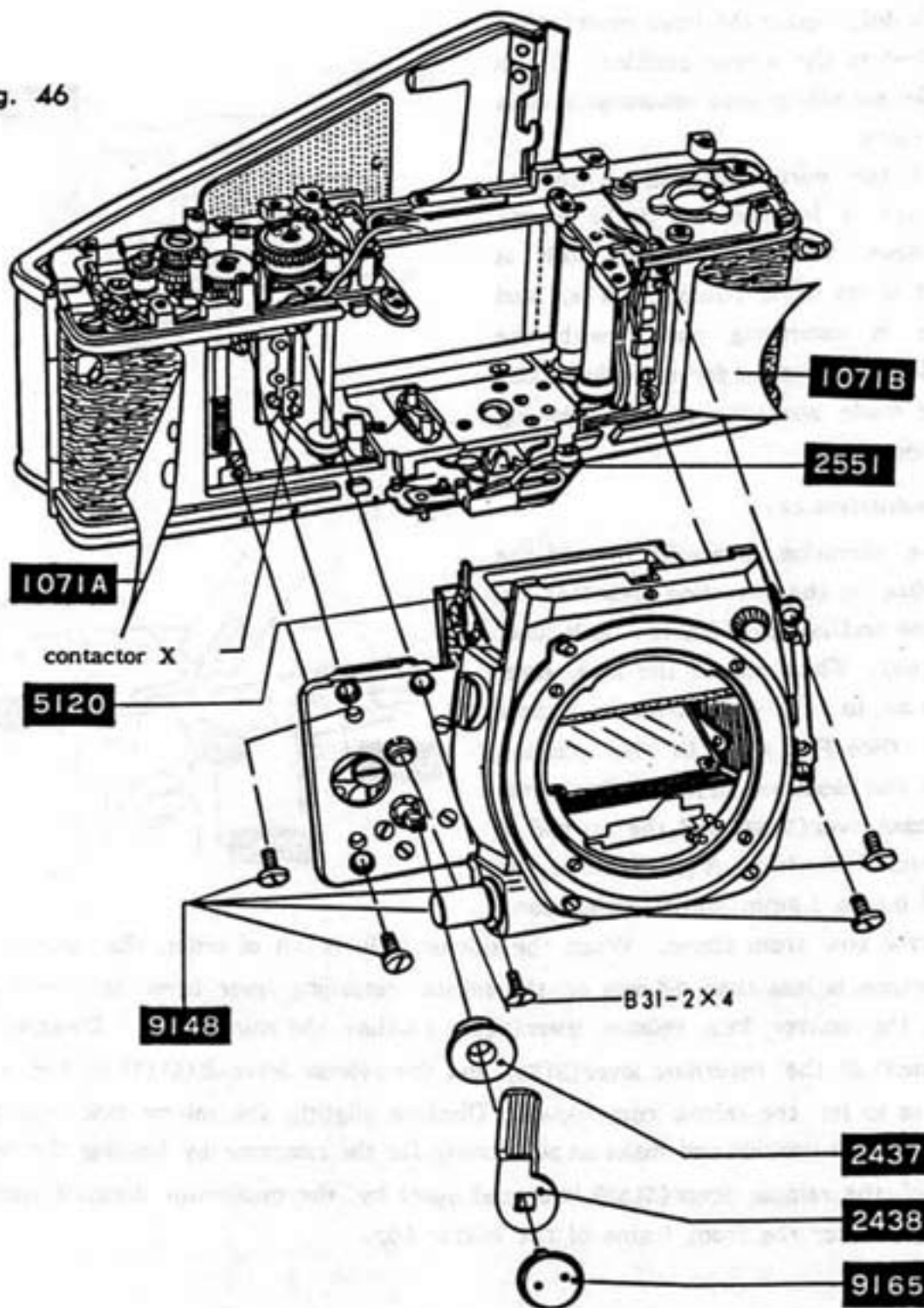

1. Release the shutter and push the mirror operation lever-A (5153) of mirror box to arrow way then hook the hook lever plate (5169) to operation lever-A and set free the hook lever plate (5169) also keep the mirror in its clear position. Hold the support starting lever (5125) by your finger and withdraw the coupling string (4080) upwardly of the camera body. Coincide the slot of the molt plane at the bottom of the mirror box to the pre-set lever-A (2551) of the camera body so that the front base plate (1002 set) may be fitted into the camera body. Release the lever of self-gear from the hole in the front side of the base plate (1002 set) and tighten four setscrews (B11-2×3.5).

Fig. 47

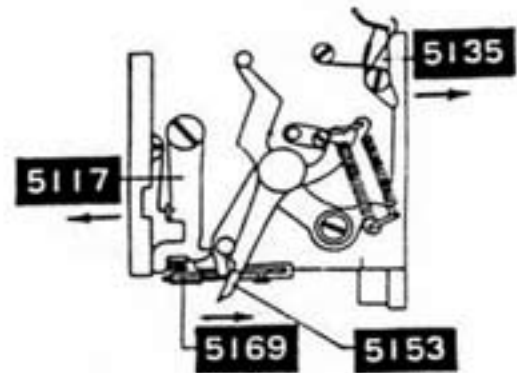

2. Body back adjustment: Set the shutter speed dial to B, than stay open the shutter curtain, next open the back cover and place the mask cover scale anvil with its projection portion being positioned at the right. Fit the body over the projected portion of the mask cover scale anvil and place the dial guage upon the washer place. Then, slide the dial guage up and down, to the right and left and further along the diagonal lines and measure the dimensions of the four corners. Loosen four setscrews (B11-2×3.5), and rotate four body back adjustment screws (9112) which can be seen from the opening of the front frame so that the body back may be positioned in the order of 43.7 ± 0.03 mm and the parallelism in the order of 0.02 mm. The body back adjustment screw may be raised or lowered by 0.35 mm upon one rotation of the screw. When the screw is rotated angularly about 10 degrees of angle, the screw can be raised or lowered by 0.1 mm. After adjustment, tighten one setscrew (B31-2×4) and also tighten four setscrews (B11-2×3.5).

Fig. 48

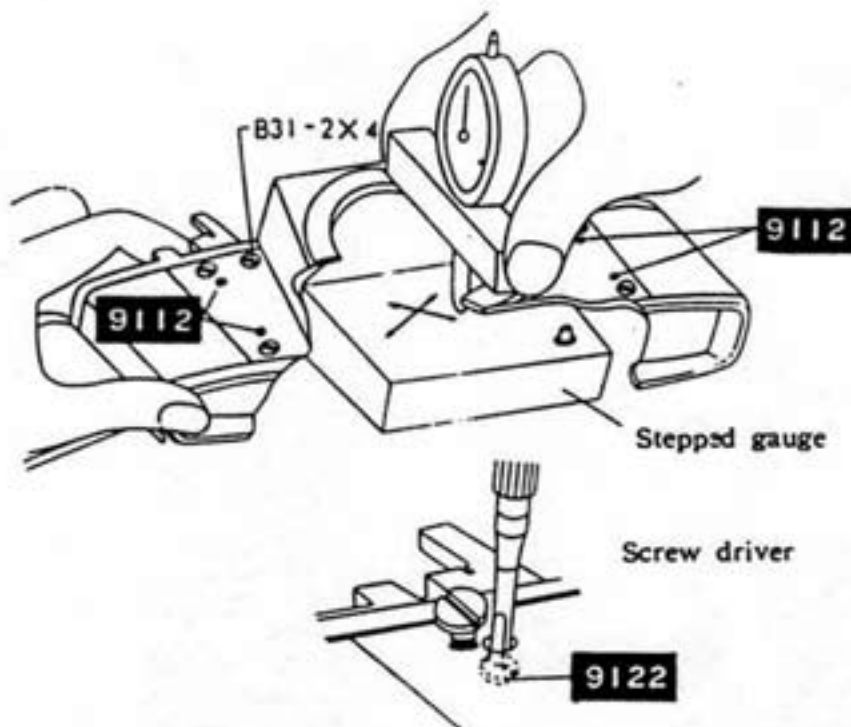

3. Mount the viewfinder and the meter block. (See P. 27).
4. Mount the winding lever to the winding base plate and then wind the winding lever. If the mirror is raised in the course of winding, the engagement between the release lever-B (2503) and the pre-set lever-B (2505) is not correctly made so that the pre-set lever-B spring (2525) must be strengthened and the release lever coupling arm (2502) must be bended for adjustment.
5. Paste over the camera body the front leather-A,B (1071-A,B) and attach the self-timer bush (2437) and the charge lever (2438). Then tighten the charge lever setscrew (9106).
6. Take off the winding lever and mount the top cover. (See P. 25)

Fig. 49

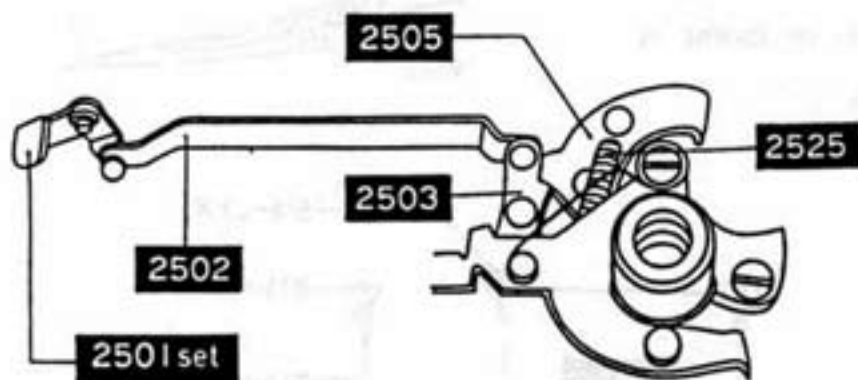

F. Mounting of Following needle base plate

1. Consolidate or place in order the lead wires as indicated in the figure. Align the elongated slot of the bottom of the rewinding shaft bearing (3351) of the needle following plate with the look plate (1151) and embed base (lead wires). Then attach the shaft bearing (3351) by means of three setscrews (B13-1.7×3).
2. Withdraw the base plate (4072) forwardly of the camera body and after inserting the lead wire (white colored) of the wire printed plate (4265 set) as indicated in the figure attach the base plate (4272) by means of two setscrews (B13-1.7×3).

Fig. 50

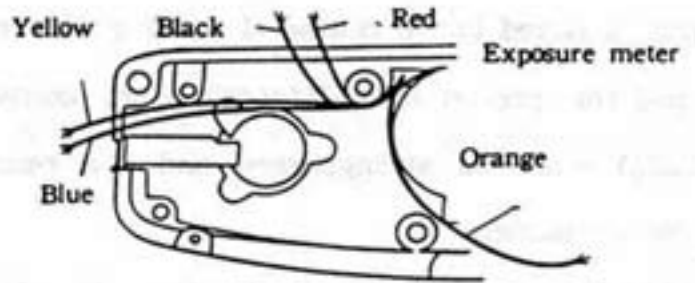

Fig. 51

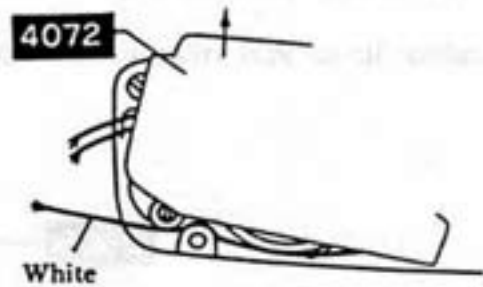
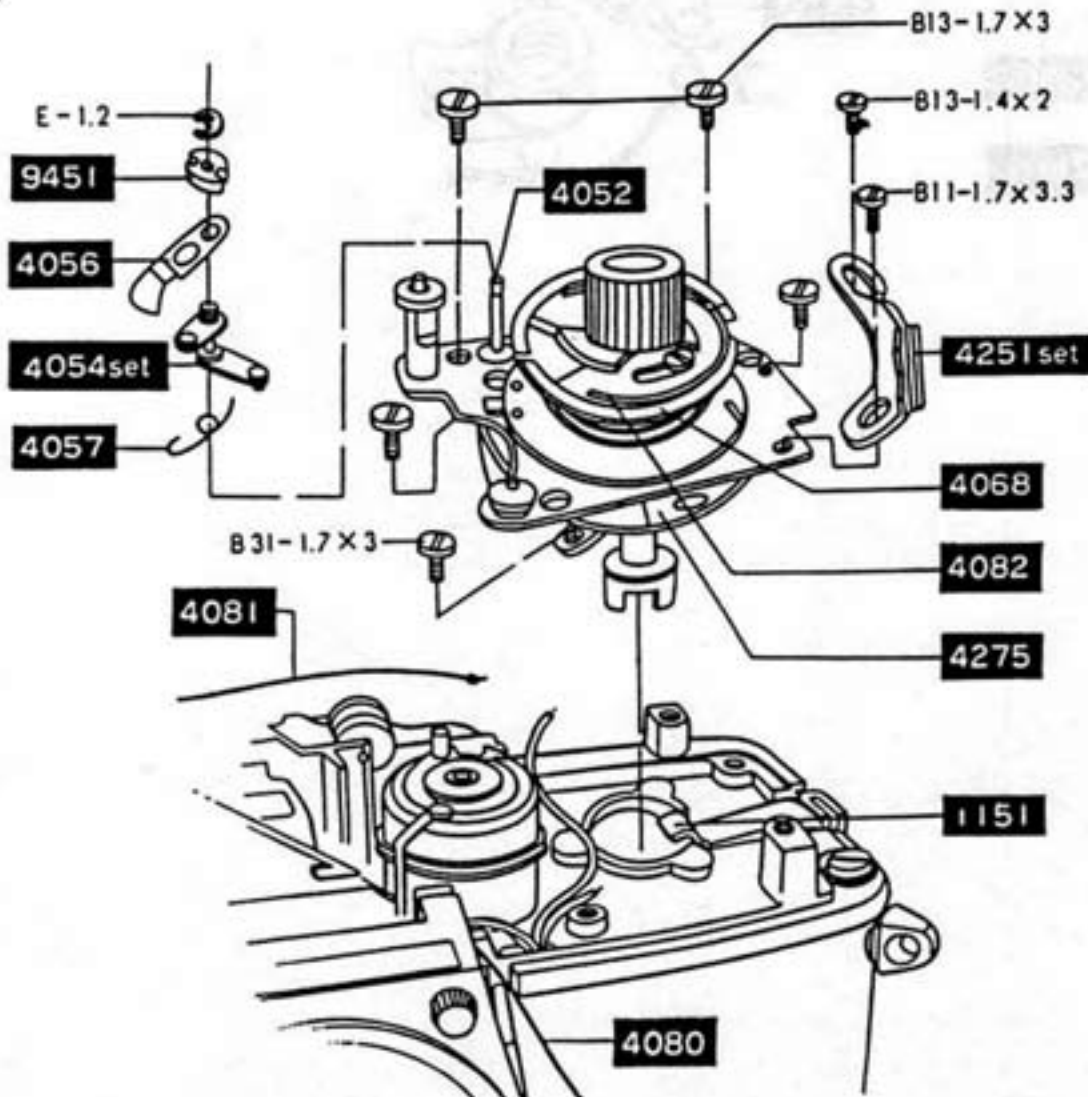

Fig. 52



3. Attachment of AV and TV strings:

Attach the MC standard F1.4/58mm lens to the body bayonet mount and set the diaphragm ring to F4. Then attach the TV pulley press nut jig (03Y-0013-79) to the rewinding shaft. One knot portion of the TV coupling string (4081) is to be inserted into the slot of the film sensitive ring (2158) of the shutter base plate-A, and then pull out the coupling string (4081) below the sensitive ring (2158). (See Fig. 53). Fix the speed dial ring (2155), the sensitive plate spring (2005), the sensitive plate sheet (2153 set) and the speed dial scale plate (2151) to the shutter base plate-A by means of one setscrew (B31-1.7×2.5). (See P. 24) Set the speed dial to 1/30 sec. and ASA 50.

Rotate about two and half turns the following pulley holder (4070) of the needle following base plate (4072 set) in the counter clockwise direction and attach the needle following cam position adjustment jig (03Y-0007-79). Rotate the aperture value pulley (4069) in the clockwise direction so that the switch lever (4058) attached to the pulley (4069) and made of bakelite is abutted against the pin of the jig plate. (See Fig. 54) The lengths of the AV coupling string (4080) and the TV coupling string (4081) are 195mm and 237mm respectively.

When they are exchanged, the permissible dimension of the knot portion must be within the order of $\pm 1\text{mm}$. Otherwise, adjustment after attaching the strings can not be made. When the strings are attached, care should be taken not to overlay the AV string (4080) and the TV string (4081) on each other.

Fig. 53

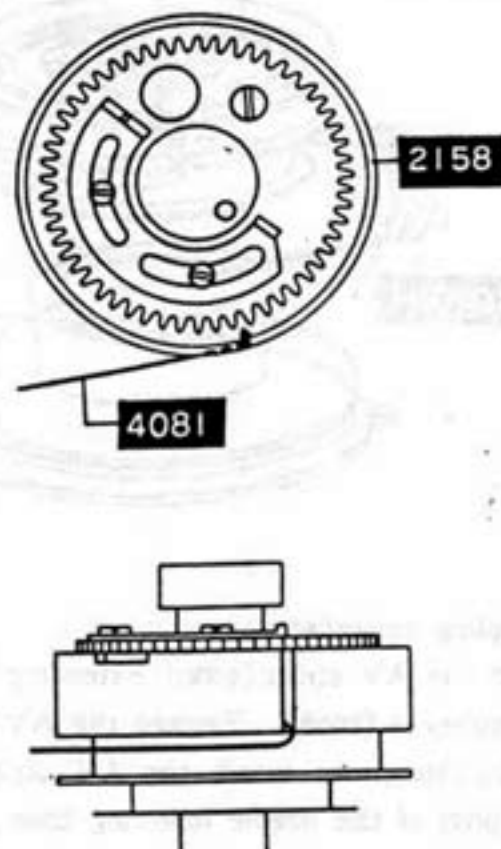

Fig. 54

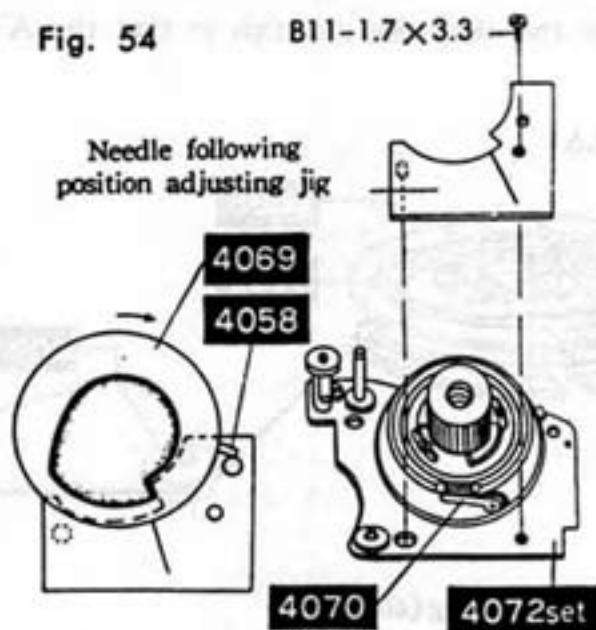
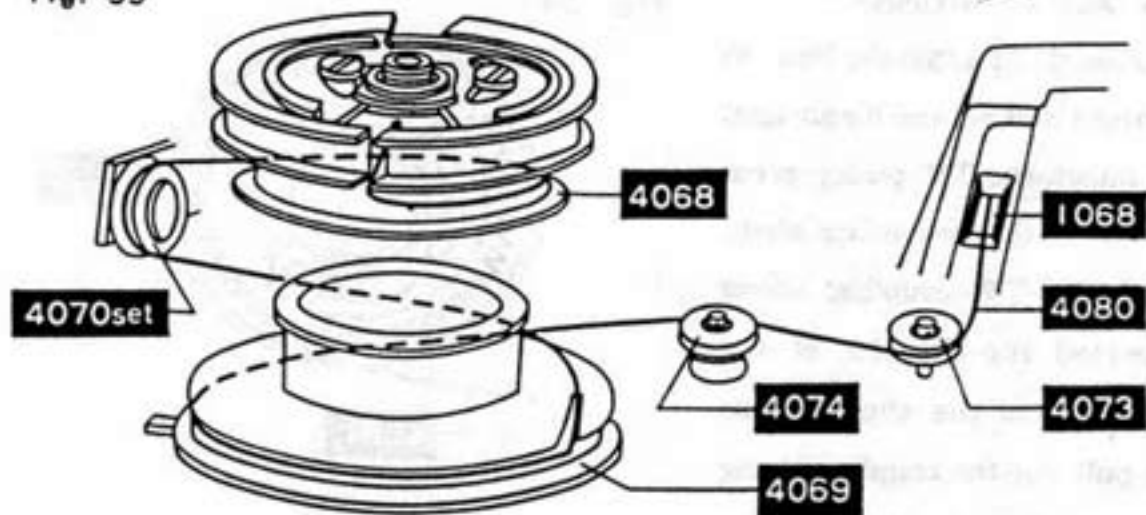

Fig. 55



4. AV coupling string (4080):

Check if the AV string (4080) extending from the front frame is not disengaged from the middle pulley-A (1068). Engage the AV string (4080) to the middle pulley band-C (4073, 4074). In this state, insert the AV string (4080) into the slot provided around the AV pulley (4069) of the needle following base plate in the clockwise direction. Insert the AV string (4080) into the slot portion of the AV pulley (4069) and then wind around the pulley of the pulley holder (4070 set) from the lower side thereof, Engage the knot portion with the upper slot portion from the beneath of the TV pulley (4068), which is then turned lightly in the clockwise direction so that the AV string (4080) may be tightened.

Fig. 56

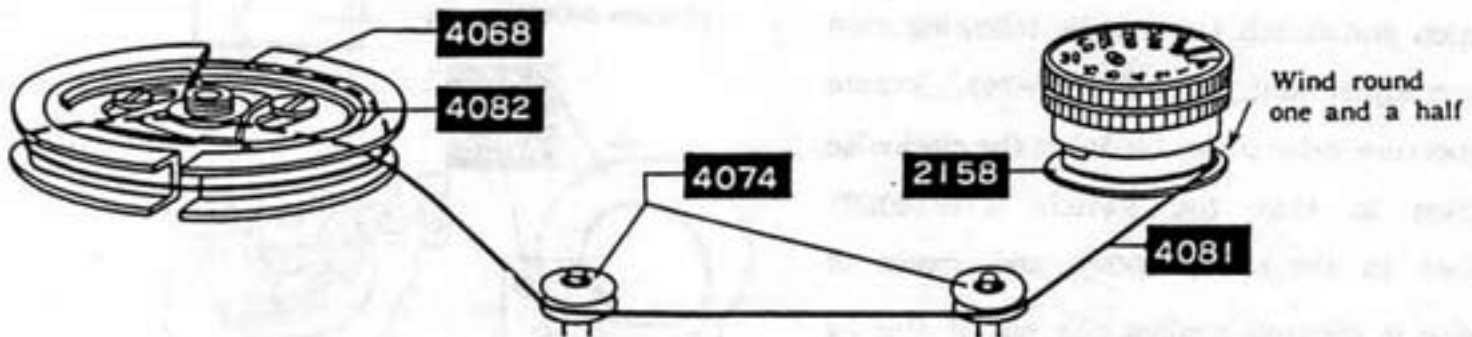

5. TV coupling string (4081):

First set the camera to EV 9, that is ASA 50, shutter speed 1/30 sec. and F4 and then wind about one and a half turn in the clockwise direction the TV string (4081) extending from the shutter base plate-A around the film sensitive ring (2158). Wind the TV string (4081) around the middle pulley-C (4074), two places, and also around the TV pulley (4068) of the needle following base plate in the counter clockwise direction about one turn. The string must be passed into the inside from the notch portion of the TV pulley (4068) as indicated in the figure and the knot portion must be engaged with the notch portion of the adjusting ring (4082).

6. Cam position adjustment :

Loosen two setscrews(B11-1.4×1.6) of the adjusting ring(4082) and rotate the TV pulley(4068) in the clockwise direction and the adjusting ring(4082) in the counterclockwise direction so that the AV and TV (4080, 4081) may be tightened. The knot portion and the portion inserted in the slot of the AV string(4080) are pasted to hold it in position. Paste the only knot portion of the TV string(4081). Set the camera to EV 10, that is ASA 50, shutter speed 1/60 sec. and F4 and loosen two setscrews(B11-1.4×1.6) to move the adjusting ring(4082) for adjustment so that the straight portion of the following pointer coincides with the EV 10 line of the following cam position adjustment jig(03Y-0007-79).

7. Insert into the needle following axis(4052) of the base plate(4072 set) the following return spring(4057) with its bended portion being facing upwardly, and the insert the needle following rotate axis(4054 set). Engage the return spring(4057) with the rotate axis(4054 set) as indicated in the figure, and insert the following upper lever(4056). Then, tighten the following lever nut(9451) and fit the coupling washer(E-1.2) into the notch portion of the following axis(4052).

8. Needle following lever opening angle adjustment :

This is the adjustment for calibrating the errors and deviation of the following cam and the meter following needle. Set the camera to EV 10 that is ASA 50, shutter speed 1/60 and F4 and then adjust by rotating the upper lever eccentric pin(9208) of the rotate axis (4054 set) so that the following needle within the meter may coincide with the checker point in the figure.

9. Take out the lens or connecting ring F4 set jig and the following cam position adjustment jig.

Fig. 57

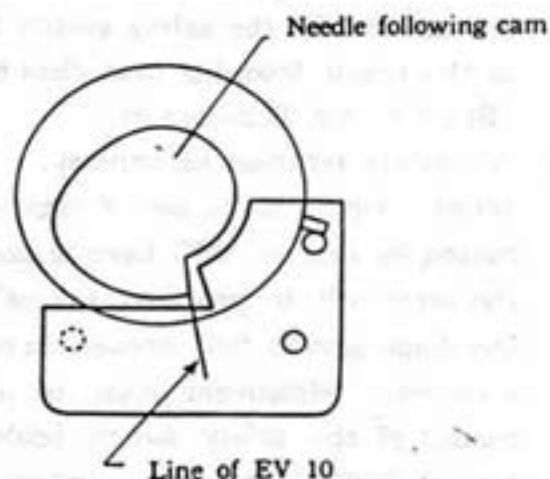

Fig. 58

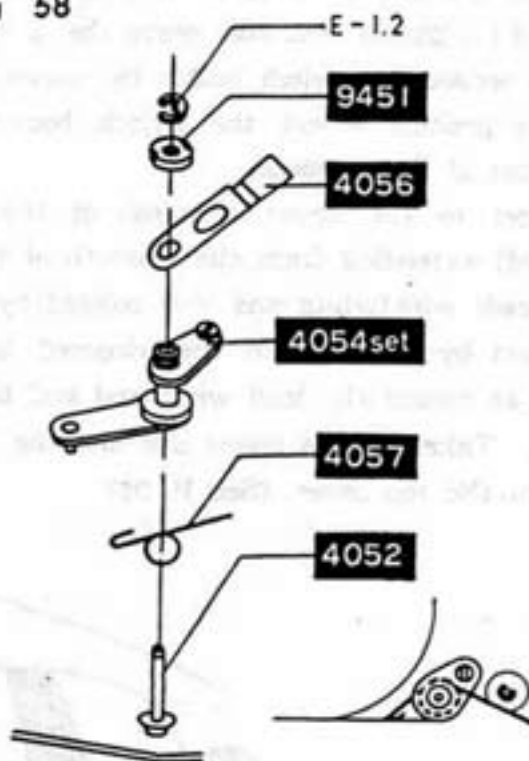
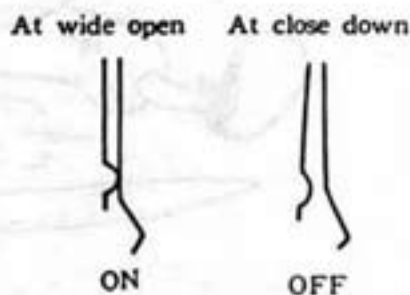
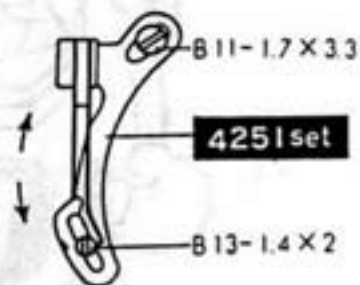
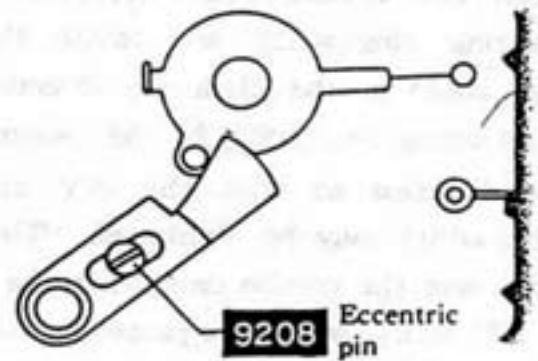

Fig. 59



10. Set temporarily the safety switch holder(4251 set) to the needle following base plate by two setscrews (B11-1.7×3.3, B13-1.4×2).
11. AV safety terminal adjustment :
When taking a photo and depressing the pre-view button in case of MC Lens(erroneous operation), the error will be produced except the case when the diaphragm is fully opened. In order to eliminate such error, adjustment must be made so that the contact of the safety switch holder(4251 set) will become "OFF" when the coupling ring of the camera body is deviated from the fully opened position by even a little distance. Attach to the camera body the MC standard F1.4/58mm lens and move the switch holder(4251 set) forwardly and backwardly. Then secure the switch holder by means of two setscrews(B11-1.7×3.3, B13-1.4×2) at such a position where the switch becomes "OFF" on the MC standard lens diaphragm ring out of F1.4 position.
12. Connect to the upper terminal of the switch holder(4251 set) the lead wire (black colored) extending from the beneath of the base plate(4072) and to the lower terminals the leads wire(white and blue colored) by soldering.
13. Connect by soldering to the wirecord lug plate(4275) below the following needle base plate or mount the lead wires(red and blackcolored) from the front side of the camera body. Take out the speed dial and the TV pulley press nut.
14. Mount the top cover. (See P. 25)

Fig. 60



G. Mounting of Aperture setting mount

Check point before mounting :

* Make it sure that the reducing lever plate spring (2574) of the aperture reducing base plate (2571 set) is bended as illustrated in the figure and that the reducing rub plate (2572) must slide lightly when the rub plate (2572) is rotated in the direction indicated by the arrow in the figure.

1. Insert the charge lever axis receiver (3157) into the charge lever-B (3169) of the bottom of the camera body. Move the rub plate (2572) of the base plate (2571 set) to the direction indicated by the arrow in the figure 61 so as to abut against the rub plate axis-A (9363), and in this state mount the reducing lever plate spring (2574) by one setscrew (B11-2×3.5) to the camera body so that the spring (2574) may extend forwardly of the pre-set lever-A (2551) of the camera body. (Because of lack of figure, this item may be mistranslated.) (See Fig 63.)
2. Set the charge lever-B axis (9052) to the base plate (2571 set) and insert the rub plate spring (2580) and the charge lever-B spring (3170) into the charge lever-B axis (9052) for engagement as indicated in the Fig. 62. Insert the coupling plate spring (2582) into the shoe rivet pin-F (9380) and engage as indicated in the Fig. 62.

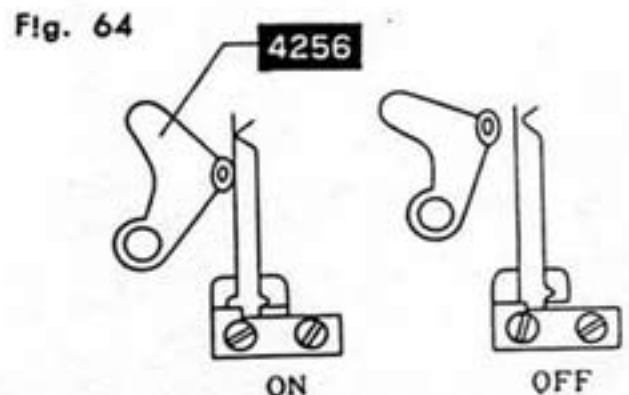
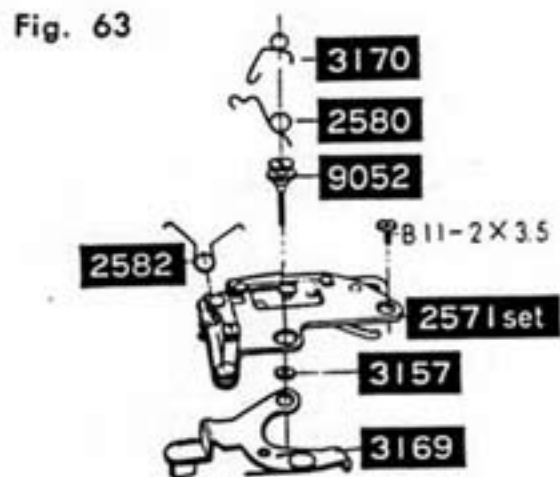
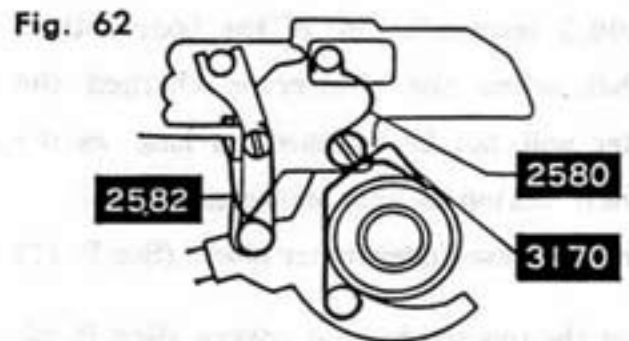
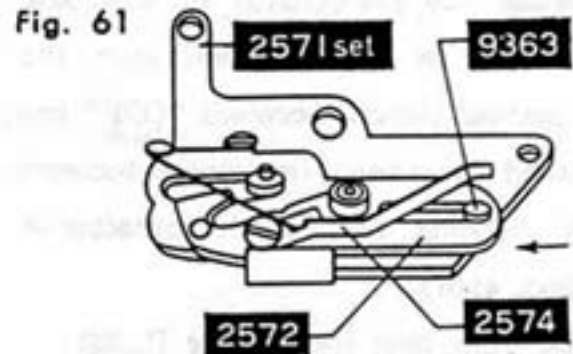

3. The shutter of the camera body is cocked and then adjustment must be made so when the reducing rub plate(2572) of the base plate(2571 set) is pushed down once the aperture setting switch becomes "OFF" and when pushed down again the switch becomes "ON" by bending the switch contactor-A and B(4260, 4261).
4. Mount the front base frame. (See P. 35)
5. Adjust by rotating the support lever adjusting pin(9385) (eccentric pin) of the body bottom so that when the shutter is charged the shutter will not be released as long as the pre-view button is kept depressed.
6. Mount the view-finder meter block. (See P. 27)
7. Mount the top and bottom covers. (See P. 25)

Fig. 65

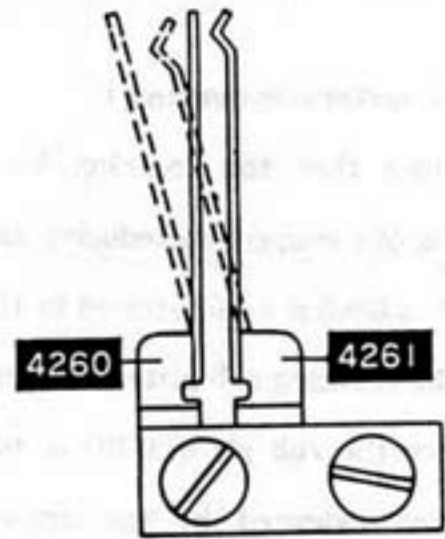
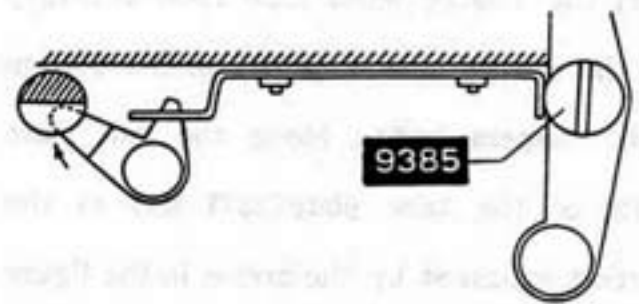

Fig. 66



4. Mounting of Shutter base Plate-A and Slow gear

Check point before mounting :

- Check if the second gear (2308) of the slow governor will return to its initial position when the part is displaced in the direction indicated by the arrow in the figure to its full extent.

Fig. 67

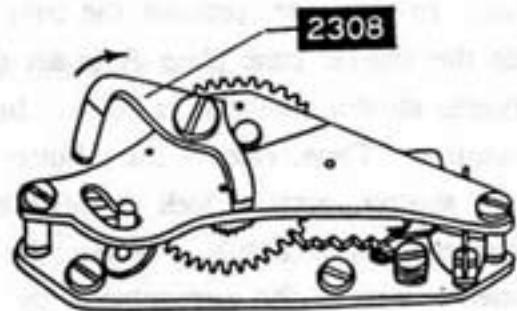

1. Engage two black lead wires of the body to the screw-A (9109) as indicated in the figure and withdraw the white and brown lead wires forwardly of the camera body. (Fig. 68)
2. Embed the shutter base plate-A (2049 set) into the camera body and hold in position by one setscrew (B19-1.7x4.2). Place the cord holder (2263) upon the base plate-A (2049 set) and hold them in position by one setscrew (B19-1.7x4.2).
3. Attach the speed dial stopper (2159 set) by the pulley base axis-A and B (9153, 9156), and then place the TV middle pulley base (4077 set) over the speed dial stopper (2159 set), and hold them in position by two setscrews (B11-1.7x2.5).

Fig. 68

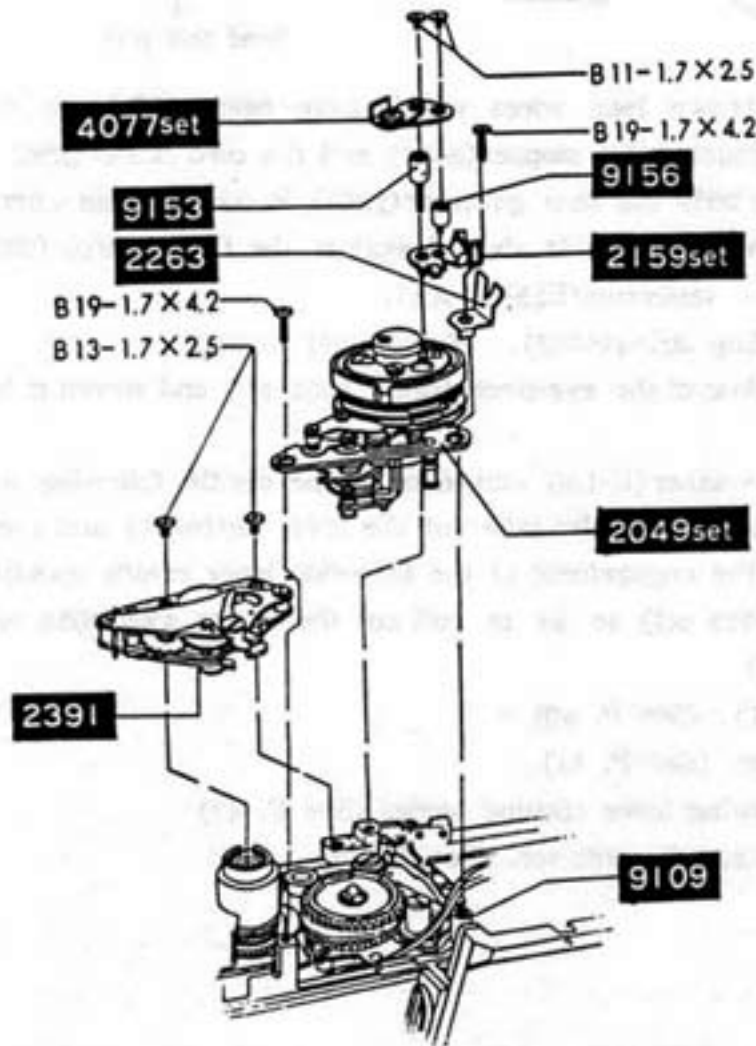

4. Mount the winding lever to the winding lever holder. Set the shutter base plate-A to bulb position, and release the shutter. In this case, if the shutter curtain fails to close or run, this is because the sliding motion of the second shutter curtain lock lever(2029) and the clutch fork(3024) is not smooth. Adjust by bending the bended portion of the clutch fork (3024). Further, if the shutter axle spring is too weak, the shutter curtain fails to close or run. In this case, pull out the split washer and expand the spring.
5. When the shutter base plate-A is set the bulb position and when the shutter is released, highspeed shutter operation is made. In this case, disengage the slow gear and then charge the shutter. Then, release the shutter while checking the state of engagement of the second shutter curtain lock lever(2029) and the second curtain cock plate(2030). When the engagement is not sufficient, improve the engagement by bending the shutter curtain lock lever(2029). Even if such counter-measure fails to correct the engagement, replace the driving gear (2042 set) with new one.

Fig. 69

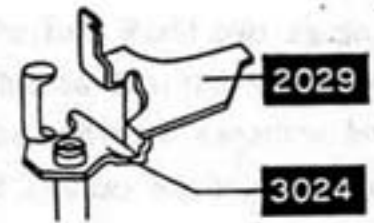
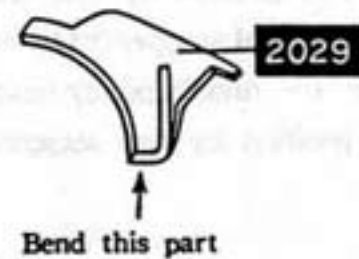
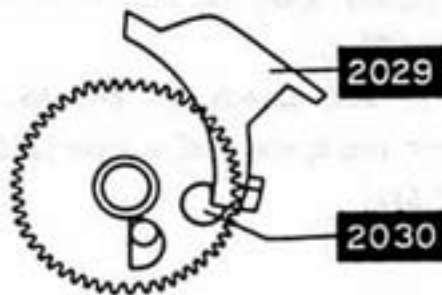

Fig. 70



6. Insert the white and brown lead wires which have been withdrawn forwardly of the camera body into the counter dial stopper(3453) and the cord holder(2263).
7. Embed into the camera body the slow governor(2391) in such a state where the settlement lever(2326) of the governor(2391) is abutted against the first gearpin(2335), and hold in position by means of two setscrews(B13-1.7×3).
8. Attach the index coupling string(5053). (See P. 29)
9. Clean the view-finder glass of the eye-piece frame(5061 set) and mount it by two setscrews (9158).
10. Take out the coupling washer(E-1.2) embedded in the needle following axis(4062) of the needle following base plate then also take out the lever nut(9451) and the following upper lever(4056). Release the engagement of the following lever return spring(4057) with the following rotate axis(4054 set) so as to pull out the rotate axis(4054 set) and take out the return spring(4057).
11. Attach TV string(4081). (See P. 40)
12. Adjust the cam position. (See P. 41)
13. Adjust the needle following lever opening angle. (See P. 41)
14. Adjust the AV safety switch contactor. (See P. 42)

15. Shutter speed adjustment :

Make it sure that the slow governor is not engaged when the shutter is released at such high speed from 1/1000 to 1/60. If the slow governor is engaged, adjust by rotating the eccentric pin of the slow adjustment lever (1/8 adjustment) so that the slow gear may not engage. The shutter curtain speed variation must be in the order of 30%.

- Measure the shutter velocity at 1/60 sec. Adjust by means of the second shutter curtain spring so as to obtain the curtain time from 13.5 to 14mm sec.
- Adjust the forward and backward openings by the spring of the first shutter curtain.
- Measure the shutter speed at 1/500 sec. Adjust the shutter speed by means of the eccentric pin.
- Measure the shutter speed at 1/1000 sec. Adjust the shutter speed through the hole of the shutter dial and also confirm the shutter curtain velocity variation.
- Also check the shutter speed at 1/250 sec., 1/125 sec. and 1/60 sec.
- Measure the shutter speed at 1/8 sec. Adjust the slow adjustment eccentric pin of the slow governor.
- Also check the shutter speed at 1 sec., 1/2 sec., 1/4 sec. and 1/15 sec.
- Measure the shutter speed at 1/30 sec. Adjust the split pin of the slow speed cam (2015).
- Check and adjust bulb, time and shutter curtains bound.

Fig. 71 1/1000 sec adjusting hole

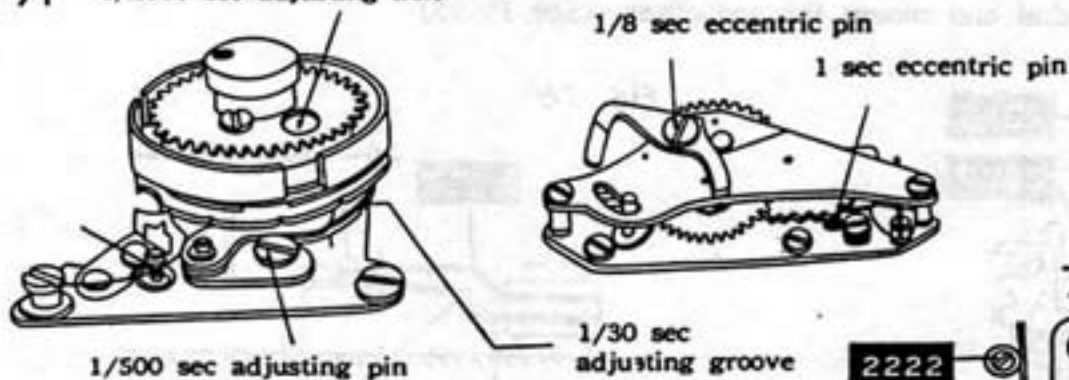

Fig. 72

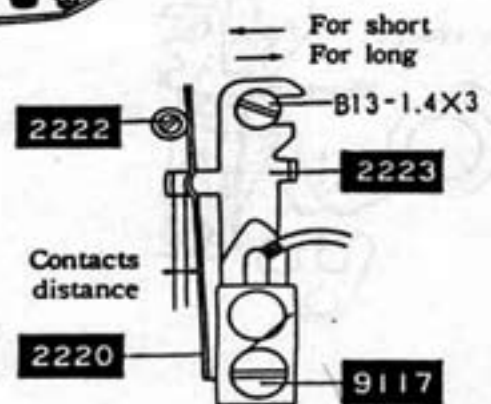
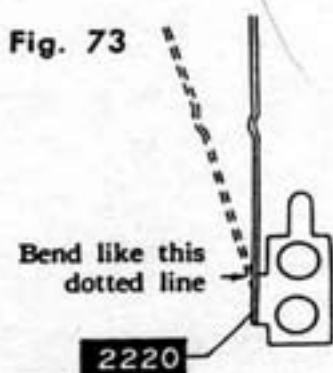

Fig. 73



16. Adjustment of time lag :

- When FP time lag is too short, loosen the setscrew (B13-1.4X3) of the FP earth contactor (2223) attached to the underside of the shutter base plate-A and push the earth contactor (2223) in the direction opposite to the terminal side of the FP contactor (2220) so that the terminal distance between the earth contactor (2223) and the FP contactor (2220) may be shortened.
- When FP time lag is too long, widen the terminal distance between the earth contactor (2223) and the FP contactor (2220).
- When the contact efficiency is too low, bend

the waist portion of the FP contactor (2220) so as to increase the contact pressure.

- * When switching-in of X time lag is too soon, adjust the contactor distance as is the case of FP adjustment. Remove the front base frame and widen the distance between the X-contactor-B (2217) of the X-contactor holder (2211 set) and the X-contactor-A (2215).
- * When switching-in of X time lag is too slow, shorten the distance between the X-contactor-B and A (2217, 2215).
- * When the contact efficiency of X contactor is low bend the waist portion of the X-contactor-B (2217) so as to increase the contact pressure.

Fig. 74

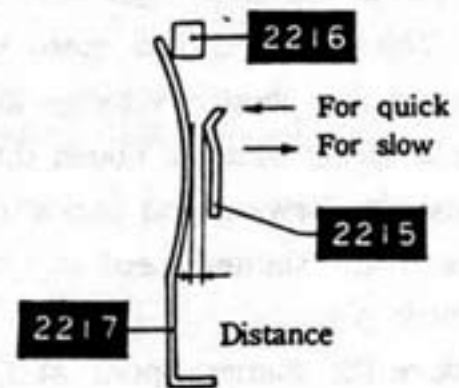

17. Conduct current test.

18. Intermediate terminal distance adjustment. When the shutter is charged, it happens sometimes that the FP contactor (2220) of the FP terminal comes to contact with the FP earth contactor (2223), resulting in short-circuiting. Therefore, the distance between the earth contactor (2223 set) from the front side of the camera body must be so adjusted to be in the order of 1 to 1.2mm as illustrated in the figure.

19. Remove the shutter dial and mount the top cover. (See P. 25)

Fig. 75

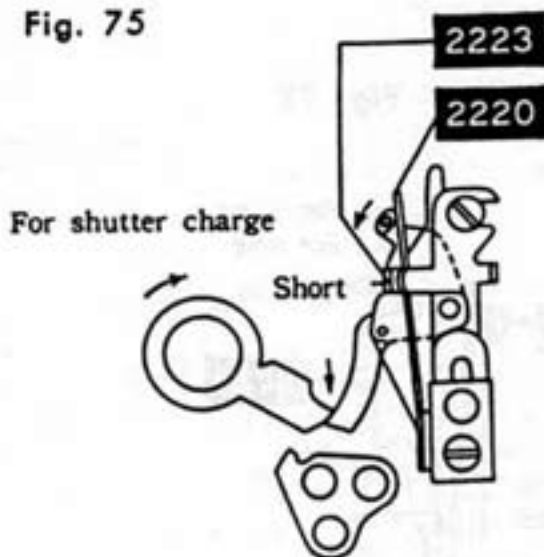
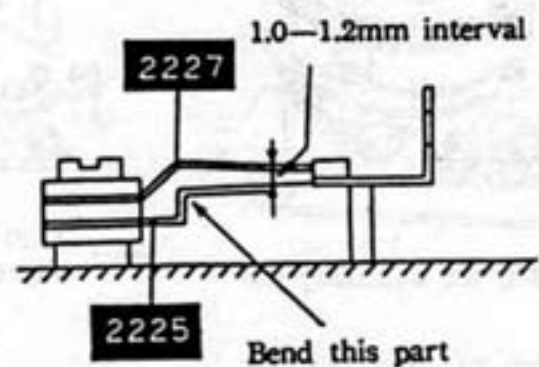

Fig. 76



I. Mounting of Winding base plate

1. Open the back cover and align the operation nail base plate(3406) of the wind-up base plate(3023 set) with the projection portion of the film spool shaft(3031) and hold it in position by two setscrews (B13-2×3.3).
2. Mount the idle support bearing(3165) setscrews(B13-1.7×2).
3. Engage the counter returning spring(3411) the under of the counter dial with the slot of the counter release lever axis(9270) and rotate in the counterclock-wise direction the counter dial. Then close the back cover.
4. Attach to the winding stopper(3027), the dial stopper supporter-B(9107), over which is positioned and held firmly by two setscrews(B21-1.7×3), the stopper unflexing plate(3168 set).
5. When the winding lever is mounted and winding is made a few times, wind-up cannot be made smoothly. In this case, iron powder or the like is dust within the idle gears, sprocket gears, etc. Therefore, clean such components so as to let them free from such foreign material.
6. If shock is felt when winding is made and when the shutter button is released, remove the counter dial component. Then insert a driver from the hole of the wind-up base plate(3023 set) and rotate the reversing stop nail axis(9263) for adjustment, the stop nail axis being observed from the opening. (See Fig 78)

Fig. 77

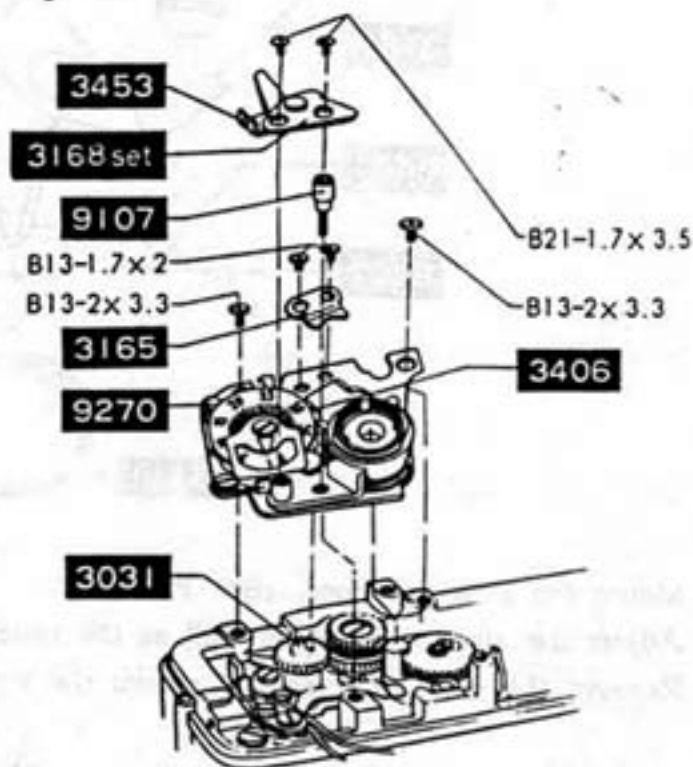
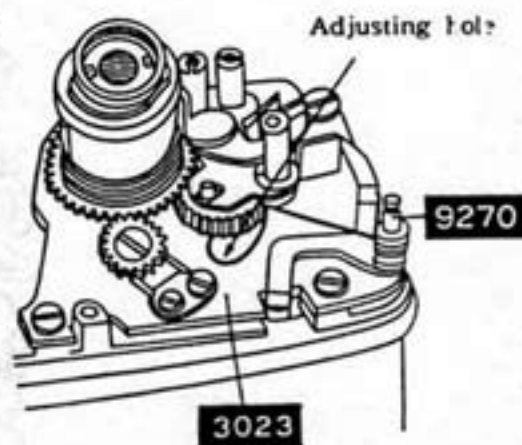

Fig. 78



7. Adjustment of counter dial:

Open the back cover and return the counter dial to the S position. Loosen one setscrew (B21-1.7×3.5) of the stopper unflexing plate(3168) and withdraw the counter dial stopper (3453) to its full extent of adjustment outwardly of the camera body. Then close the back cover, then the counter stop nail(3408) is fitted in the counter ratchet gear(3404) as shown in the figure 78. From this state, move the counter dial stopper(3453) slowly

J. Mounting of Film take-up spool

1. Open the back cover and place the decoration ring spring washer (3039) and the spool decoration ring (3037) upon the film spool (3032). In this state, assemble them into the camera body.
2. Insert the film spool shaft (3031 set) from the upward of the camera body and hold it in such position where the elongated slot of the film spool (3032) may be facing upwardly. Then, rotate the spool shaft (3031 set) and align the hole of the film spool (3032) and the threaded hole of the spool shaft (3031 set) so as to screw one setscrew (B21-1.7×4.5) for mounting. Hold in position the spool gear (3162) and then rotate in the clockwise direction on the film spool (3032) so as to align the notch portion of the film spool (3032) with the tapped hole for screwing one setscrew (B51-1.7×2.5).
3. Arrange and dispose the projection of the spool shaft (3031) to face in the right lateral direction and mount at the bottom of the camera body the charge cam (3041 set) as indicated in the figure. Then, tighten the spool shaft nut (9415).
4. Mount the winding base plate. (See P. 49)
5. Mount the slow governor. (See P. 45)
6. Mount the top and bottom covers. (See P. 25)

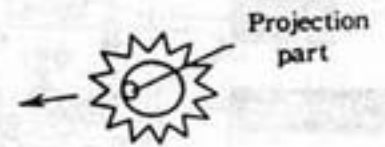

Fig. 80

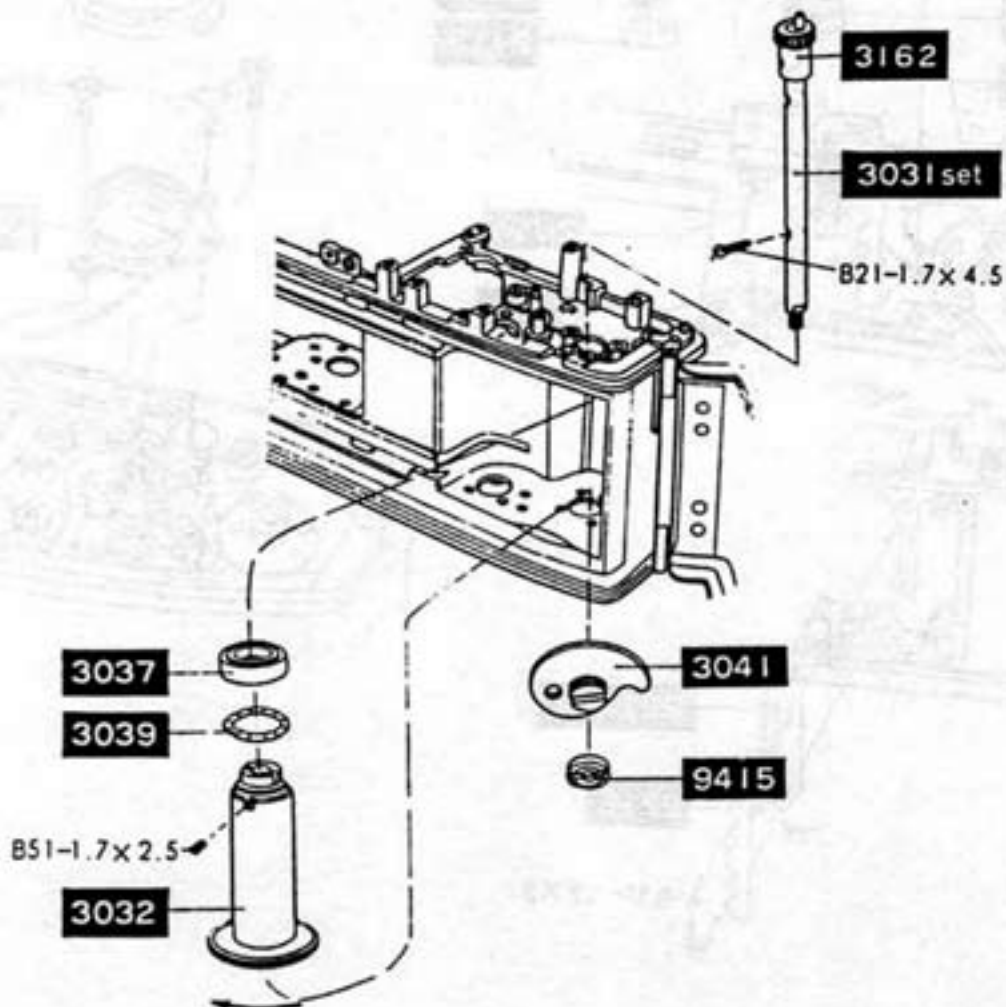
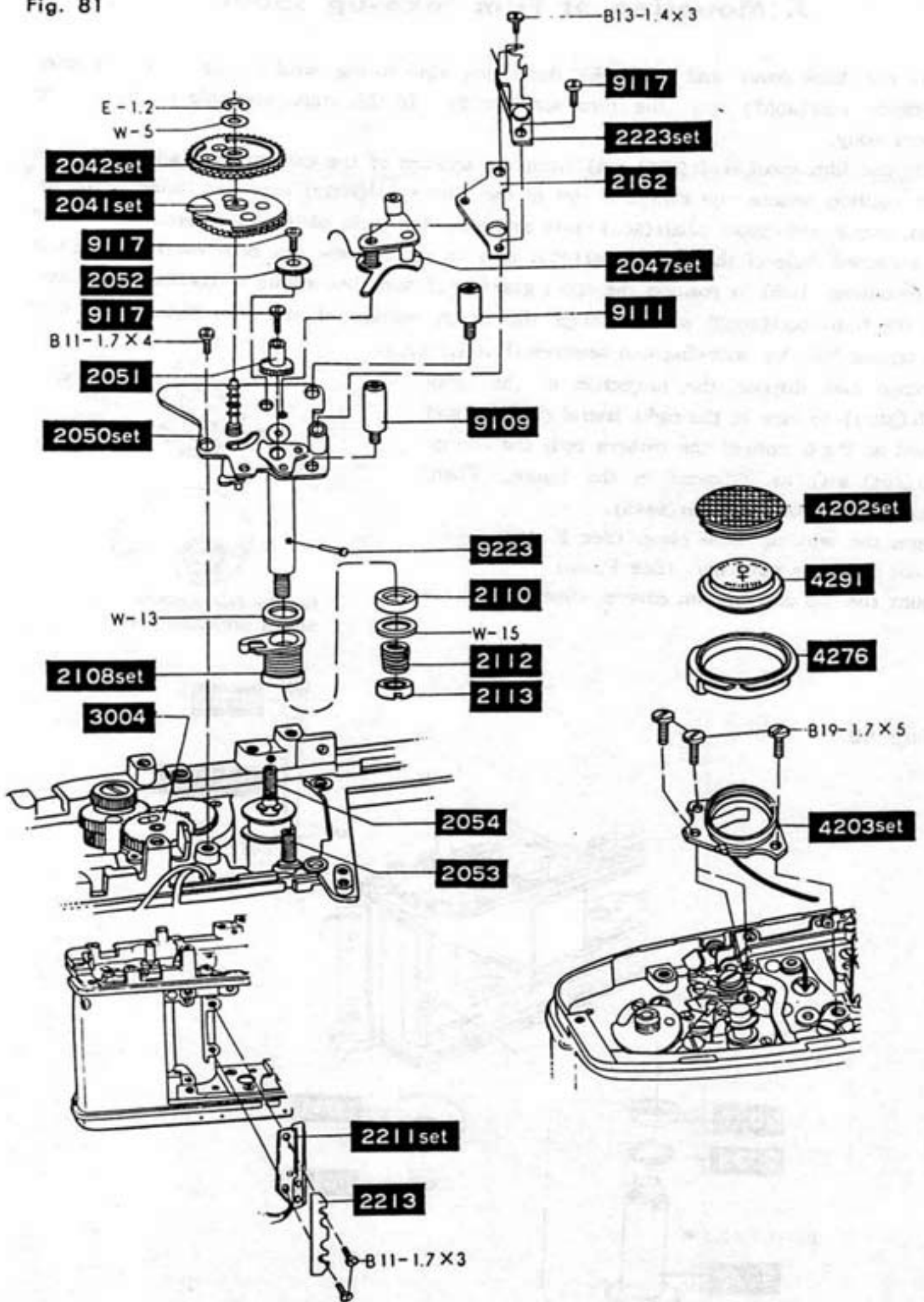

Fig. 81



K. Mounting of Shutter base plate-B

1. Insert the adjustment washers into the first and second curtain spring shaft(2060, 2061) and position the first curtain bound stop lever(2101) of the shutter base plate-B(2050 set) at a position indicated in the figure. Fit the first and second curtain spring shaft(2060, 2061) into the holes of the shutter base plate-B(2050 set) and hold them in position by three setscrews(B11-1.7×4, 9109 and 9111).
2. Pass the ribbons of the second shutter curtain transversely of the bound stop lever axis (2102 set) below the shutter base plate-B.
3. Hook the spring of the starting lever (2047 set) to the base plate-B setscrew (9111) and mount the starting lever(2047 set). Hold it so that it may not be taken off and hold the starting lever axis bearing plate(2162) and the FP earth contactor(2223 set) in position by two setscrews(B13-1.4×3, 9117). Place the earth contactor(2223 set) at such a position as indicated in the figure.
4. Attach the first shutter curtain gear(2051) to the curtain spring shaft(2060) as indicated in the figure and tighten the curtain gear setscrew(9117).
5. Attach the second shutter curtain gear(2052) to the curtain spring shaft(2061) as indicated in the figure and tighten the curtain gear setscrew(9117).
6. Make it sure that the pin of the mirror kick gear (2513) of the body bottom be placed at such a position as indicated in the figure and also dispose the bound stop lever (2101) to the base plate-B(2050 set) at such a position as indicated in the figure. Then wind the second shutter curtain axle and stop the second shutter curtain gear(2052) by your finger with the end of the second shutter curtain being aligned with the marking-off line on the left side. Then

Set position of mirror kick gear

Fig. 86

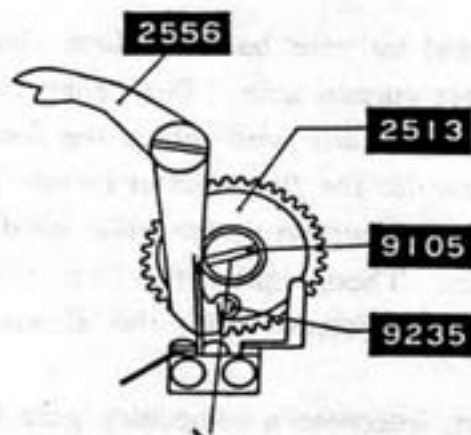

The edge of release lever must on straight line

Fig. 82

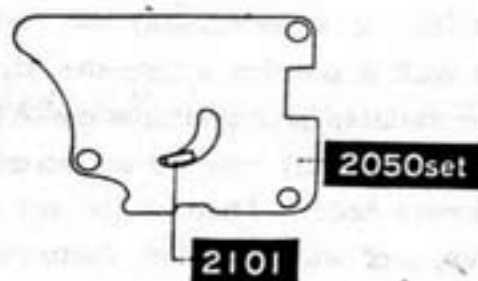

Fig. 83

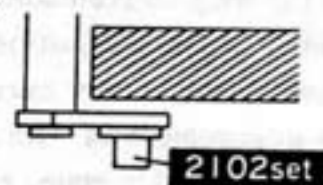

Fig. 84

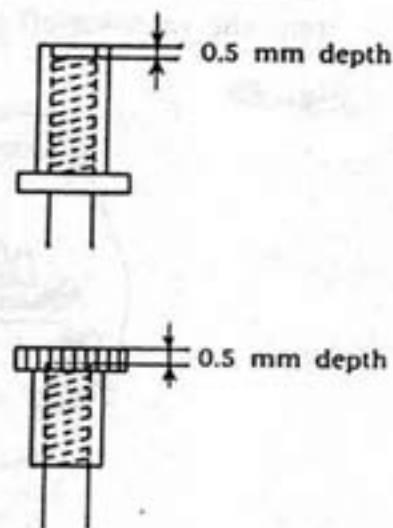
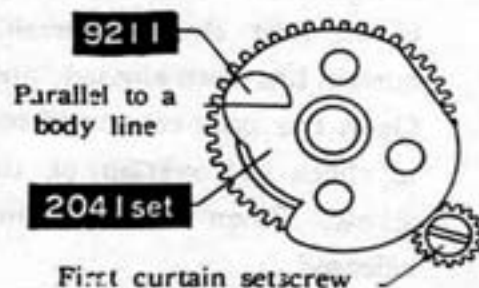
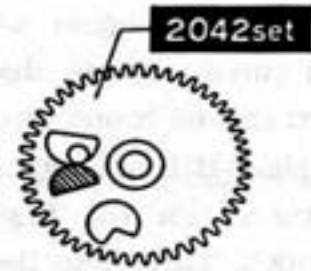

Fig 85



wind the first shutter curtain axis so that the seam line of the first shutter curtain may be aligned with the marking-off line. In this state, stop by your finger the curtain spring shaft (2060). Insert into the variable gear axis (2045) the variable gear (2041 set) in such a position where the straight line portion of the variable gear operation pin-A (9211) of the variable gear (2041 set) may be positioned in parallel with the camera body. Then let the parts held by your finger free, and wind the first shutter curtain axis and lock by means of starting lever.

Fig. 87



7. Wind up the second shutter curtain shaft in such a manner that the end of the second shutter curtain may be aligned with the seam line of the first shutter curtain. Then, insert the driving gear (2042) as shown in figure and also insert washer (W-5) and coupling washer (E-1.2) too.
8. Withdraw the starting lever and release the shutter. Loosen the kick gear bush setscrew (9105-B) located at the bottom of the camera body so that the pin of the mirror kick gear (2513) may be positioned at the center of the change-over switch as illustrated in the figure.
9. Shutter curtain adjustment :
Wind up the shutter curtains and hold by your finger the driving gear (2042). Then, release the engagement of the starting lever, then the first shutter curtain will be caused to run. Maintaining this state, check which of the first and second shutter curtains is deviated from the marking-off line marked on the camera body.

Fig. 88

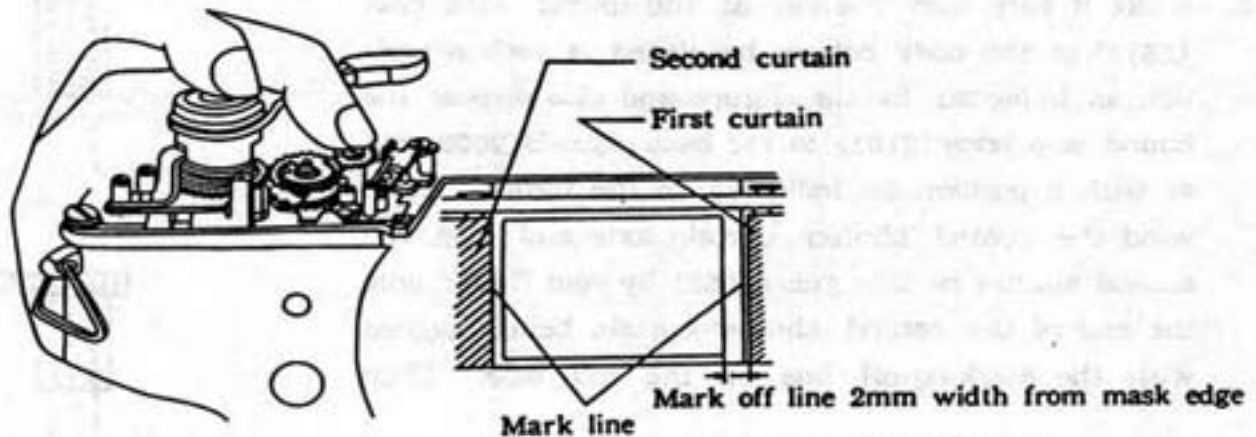

- a) When the first shutter curtain is deviated, hold by your hand the first shutter curtain axle and loosen the screw for the first shutter curtain axle. Then align the seam line of the first shutter curtain with the marking-off line with which the second shutter curtain has been aligned, and tighten the screw for the first shutter curtain temporarily. Open the back cover and rotate the second shutter curtain screw while winding in order to check the overlap of the shutter curtains. Then, tighten the first shutter curtain screw. Then second shutter curtain screw is tightened after the shutter has been released.
- b) When the second shutter curtain is deviated, interpose a temporary gear between the

driving gear and the second shutter curtain gear setscrew and wind up after loosening slightly the second shutter curtain gear setscrew. Loosen also the first shutter curtain gear setscrew slightly and hold the second shutter curtain shaft in such a manner that the marking-off line of the second shutter curtain may be seen. Then, loosen the second shutter gear setscrew further so as to rotate the second shutter curtain axis. Tighten temporarily the second shutter curtain gear setscrew at such a position where the end of the second shutter curtain is aligned with the marking-off line.

Fig. 89

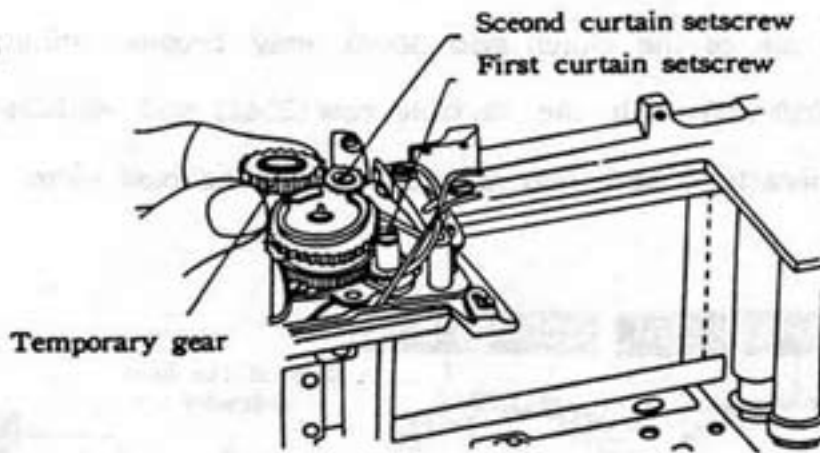

- c) Wind up the shutter curtain and check the inclination of the slit. When the inclination of the slit is rather small, adjust by pasting a piece of cloth of the ribbon to the shutter curtain axis whose curtain inclination is bigger. When the slit inclination is bigger, release the engagement of the starting lever so as to travel the shutter curtains. Then, loosen the first shutter curtain gear setscrew and rotate the first shutter curtain axis. Then, peel off the pasted portion of the ribbon and paste the larger inclination side by rather longer. Rotate the first shutter curtain axis so as to align the slit and tighten the first shutter curtain gear setscrew.
 - d) Check if the upper and lower sides of the first and second shutter curtains have slack. When there exists slack in the first shutter curtain, release the shutter first, and then adjust by pasting a piece of cloth of the ribbon over the ribbons of the first shutter curtain shaft which have slack. When there is slack in the second shutter curtain, charge the shutter and adjust by pasting a piece of cloth of ribbon over the ribbon of the second shutter curtain spring cylinder which has slack.
10. Insert into the speed dial click plate(2017) the washer(W-13) and also align and insert the transmit tube-A(2108 set) into the bound stop lever axis pin(9220). Then, fit the friction ring stopper(9223) into the hole. Align the elongated slot of the inner side of the friction ring(2110) with the head of the stopper(9223) and then insert the washer(W-15) and the brake spring(2112). Next tighten the brake spring adjusting nut(2113) until the adjusting nut(2113) may be located in the same plane with the bound stop shaft(2107).
 11. Arrange in juxtaposition two lead wires of the X-contactor holder(2211 set) so that they may not overlay on each other and in such a manner they may run along the camera body. Place a cut out portion of the holder(2211 set) over the insulating tube of the transmit tube-A(2108) and then mount the holder(2211 set) and the adjusting nut(2213) by two setscrews(B11-1.7×3).

12. Wind up the shutter curtains and open the back cover. Then, rotate the sprocket so as to position the sprocket teeth to be directed toward you, and engage the reversing stop nail (3025) into the idle gear (3003). Also place the projection of the film spool shaft (3031) in the right lateral direction. In this state, place the clutch gear (3005) of the shutter release shaft (3028 set) in such a position as indicated by the figure and press down the release shaft (3028 set) downwardly so that the distance between the oval hole of the shutter gear (3004) and the pin of the clutch gear (3005) may become minimum. Then, engage the release shaft (3028 set) with the variable gear (2041) and withdraw the lead wires forwardly of the camera body and then mount the winding base plate. (See P. 49)

Fig. 90

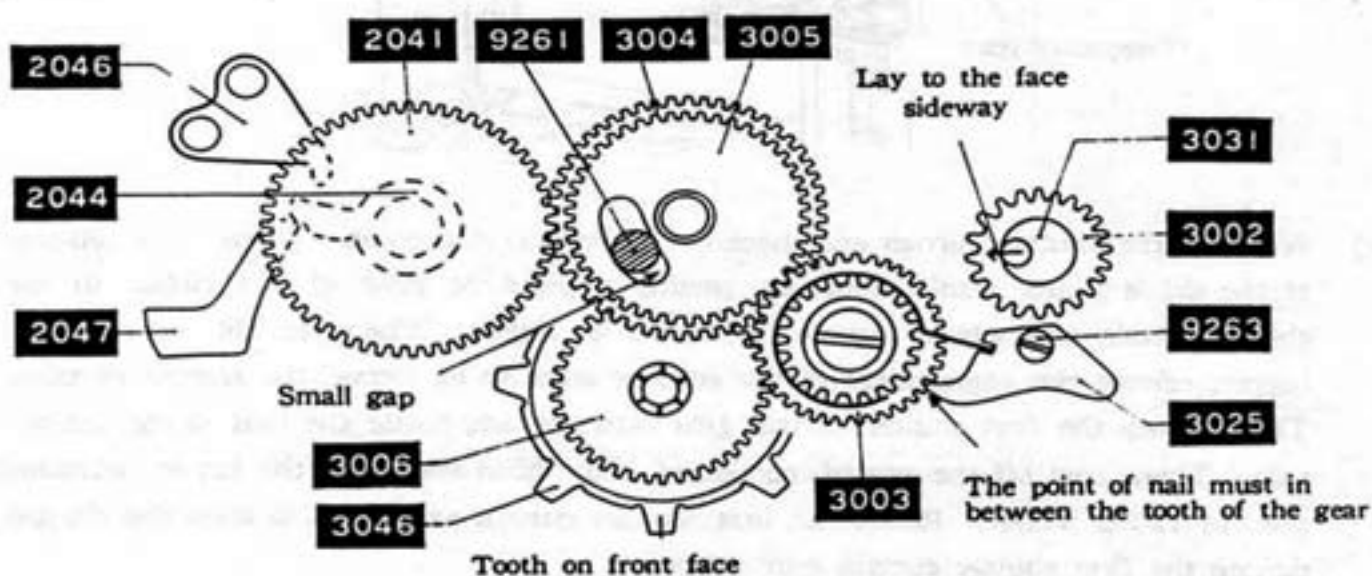

13. Mount the shutter base plate-A and the slow governor. (See P. 45)
14. Mount the front base frame. (See P. 35)
15. Mount view-finder and meter block. (See P. 27)
16. Adjust the shutter speeds and time lag. (See P. 47)
17. Check the synchro contact and adjust the distance between the middle contactors.
18. Adjustment of the brightness:

Switch "ON" the change switch of the bottom cover and mount of the camera body. Set the ASA100, shutter speed to 1 sec., Standard F1.4/58mm MC lens with its aperture being set to F5.6 (EV 5) then set the light luminescence box to EV 5, and look through the view-finder to check if the meter needle comes to rest at the center of the ring of the following needle. Also set the ASA 100, shutter speed 1/500 sec., F5.6 (EV 14) then set the light luminescence box to EV 14 and check as same above mentioned.

Intermediate check points:

Check if the meter needle comes to rest within the outer periphery of the following needle (allowance in ± 0.3 EV) at the following two points.

EV 8 (ASA 100, 1/8 sec., F5.6)

EV 11 (ASA 100, 1/60 sec., F5.6)

when the meter needle deviates out of the outer periphery deviate the EV 5 and EV 14 points so that the intermediate points may come to rest within the permissible range. Switch to B.C. the change-over switch of the bottom cover and look through the viewfinder. Rotate for adjustment the semi-fixing resistor for battery checker of bottom side of camera body, so that the meter needle comes to rest at the check point as illustrated in the Figure 92.

Fig. 91

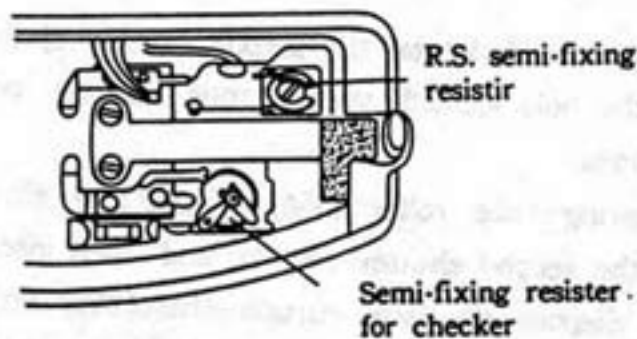

Fig. 92



19. Mount the top and bottom covers.

L. Mounting of Shutter curtains

Check points before mounting :

- * In order to check if the shutter curtains are installed in parallel, rotate the first curtain shaft(2053) in the clockwise direction as indicated in the figure so as to wind up the first shutter curtain and also check and make it sure that there is no relative inclination between the end of the first shutter curtain and the curtain shaft(2053). In the similar manner, rotate the second curtain spring tube (2063) in the clockwise direction to wind up the second shutter curtain and check and make it sure that there is no relative inclination between the curtain shaft(2053) and the second shutter curtain.
1. Place the camera body upright and locate the second curtain spring shaft(2061) of the second shutter curtain into the hole located toward your side as indicated in the figure. Then, slack a little the ribbons.
 2. Arrange and dispose the spring tube roller(2066) of the first shutter curtain so as to overlay on the ribbons of the second shutter curtain, and then insert into the hole of the camera body. Arrange and dispose the first curtain shaft(2053 set) of the first shutter curtain so as to pass between the ribbon of the second shutter curtain and further pass downwardly as illustrated curtain and further pass downwardly as illustrated in the figures.
 3. Insert the spring tube collar-B(9405) into the second curtain spring shaft(2061) of the second shutter curtain, then withdraw the curtain spring adjusting nail(2072) of the spring tube lower plate(2076 set) to such a position as indicated by the figure. Then insert the lower plate(2076 set) into the first and second curtain spring shafts(2060, 2061) and secure in position by two setscrews (B13-1.7×3).
 4. Two curtain spring adjusting nail ratchets(2073) (left handed screw) into the first and second curtain spring shafts(2060, 2061) and then hook the nail ratchet spring-A and B(2074, 2075) with the adjusting nails(2072). Rotate the both spring shafts(2060, 2061) for a few turns so as to wind up the shutter curtains.

Fig. 93

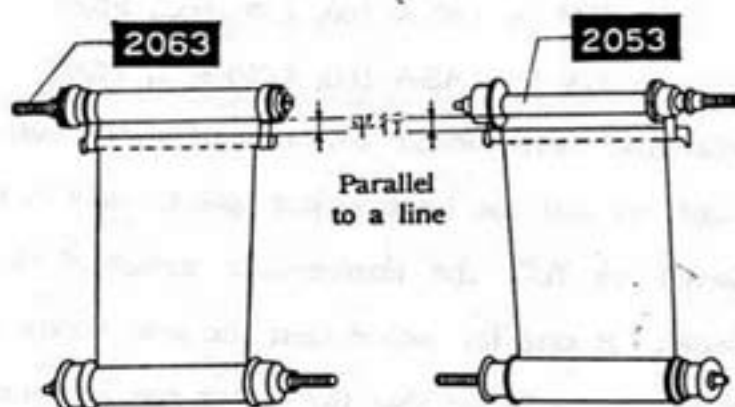
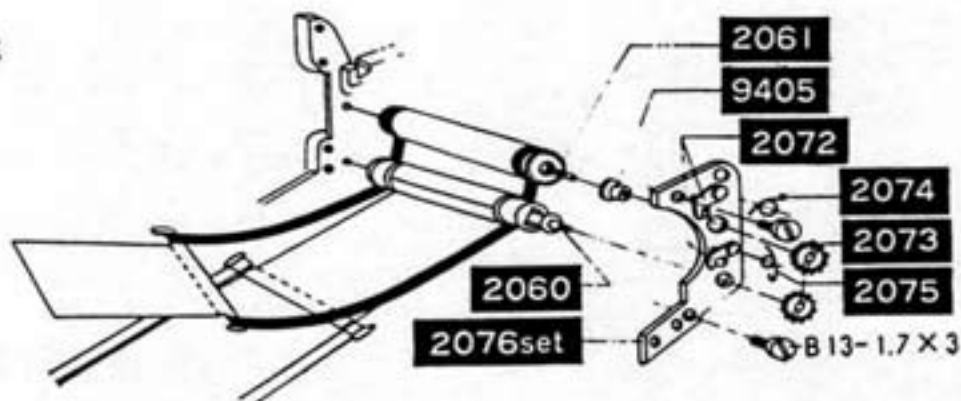
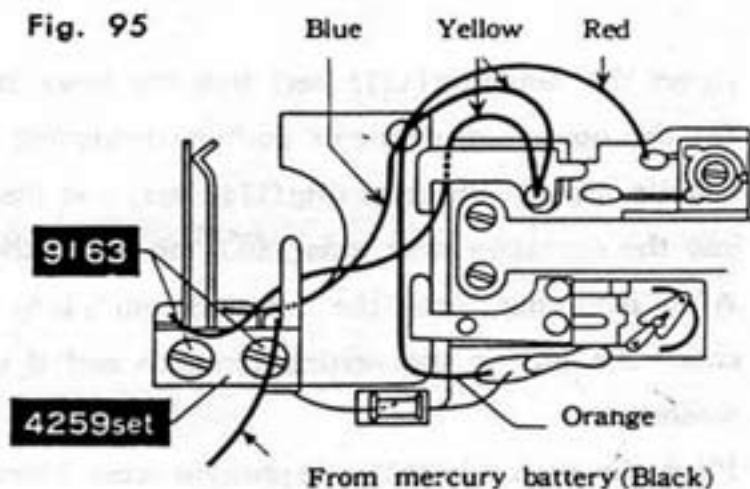

Fig. 94



5. Mount the counter isolation base (4059 set) by two setscrews (9163) and solder the lead wire (yellow colored) of the isolation base (4259 set) as illustrated in the figure. Insert the lead wires (yellow, red, orange and blue colored) into the openings of the camera body and pull them out of the hole of the spring tube lower plate (2076 set). Then, solder them in position as illustrated in the figure. Also solder in position the fixed resistor as illustrated in the figure.

Fig. 95



6. Engage the reversion lever spring (2523) with the pre-set lever stopper (2507). Insert the pre-set lever-A (2504) into the opening at the lower side of the camera body as indicated in the figure. Engage the ribbons of the first shutter curtain with the first curtain roller-A and B (2058, 2059) of the second shutter curtain, and then insert the first curtain shaft (2053) into the hole on your side.

Fig. 96

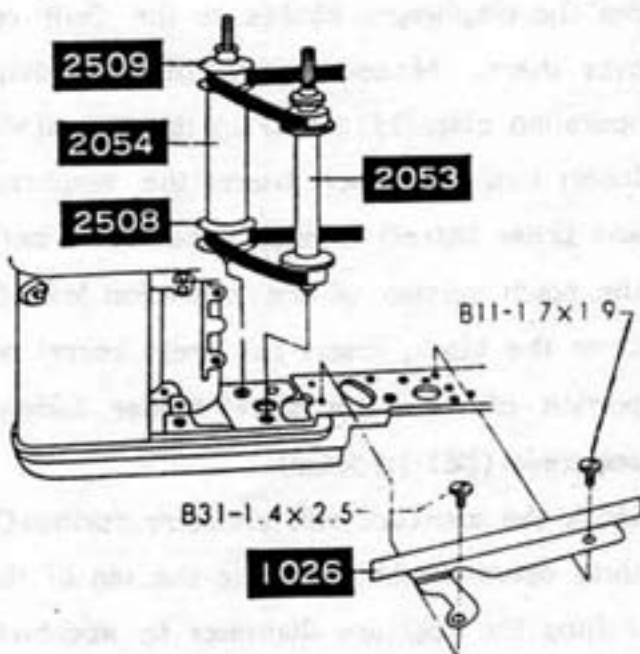

7. Stand uprightly the camera body and mount the light shield plate (1026) by means of two setscrews (B11-1.7x3, 9129).

8. Mount the shutter base plate-B.

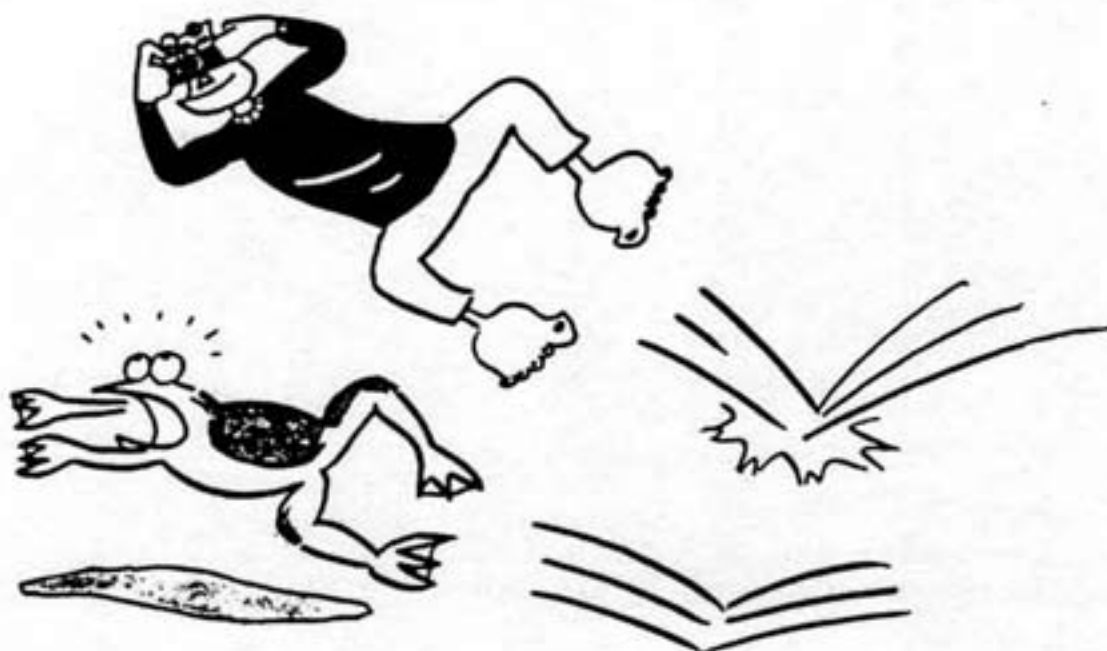

M. Assembly of Lens inner barrel

1. Insert the cam ring(1111 set) into the inner barrel(1110 set) and check its actuation.
2. Set the minimum diameter position determining jig to the inner barrel(1110 set).
3. Lift up slightly the cam ring(1111 set) and insert the diaphragm operation lever(1374 set) into the operation lever axis(1405) on which the coupling washer(E-1.9) must be attached. After mounting, hold the interlock pin(1406) of the operation lever(1374 set) so as to check the play in the vertical direction and if the play is too much, adjust by inserting the washer.
4. Place the back side of the diaphragm press barrel(1112) upwardly. Check if the diaphragm blade(1371), six blades are free from or stains and then insert them into the hole of the press barrel(1112) by means of pincette.
5. Set the diaphragm blades to the fully opened state and fit the operation plate(1113 set) over them. Make it sure that the diaphragm blades actuate smoothly by moving the operation plate(1113 set) in the lateral direction.
6. Insert into the inner barrel the diaphragm blade block(operation plate, diaphragm blades and press barrel) in such a position where the pin of the operation plate may be fitted into the notch portion of the operation lever(1374 set) which has been set in the inner barrel. Over the block, insert the press barrel holder(1115) into the inner barrel with the tapered portion of the press barrel holder facing outwardly and then secure temporarily by three setscrews(B61-1.7×2.2).
7. Hook the aperture and pressure springs(1420, 1424) as illustrated in the figure and check their operation by actuating the pin of the operation lever(1374 set).
8. Adjust the aperture diameter by aperture diameter adjuster.
9. Clean the front lens component and the rear lens component and mount them into the inner barrel.

Fig. 97

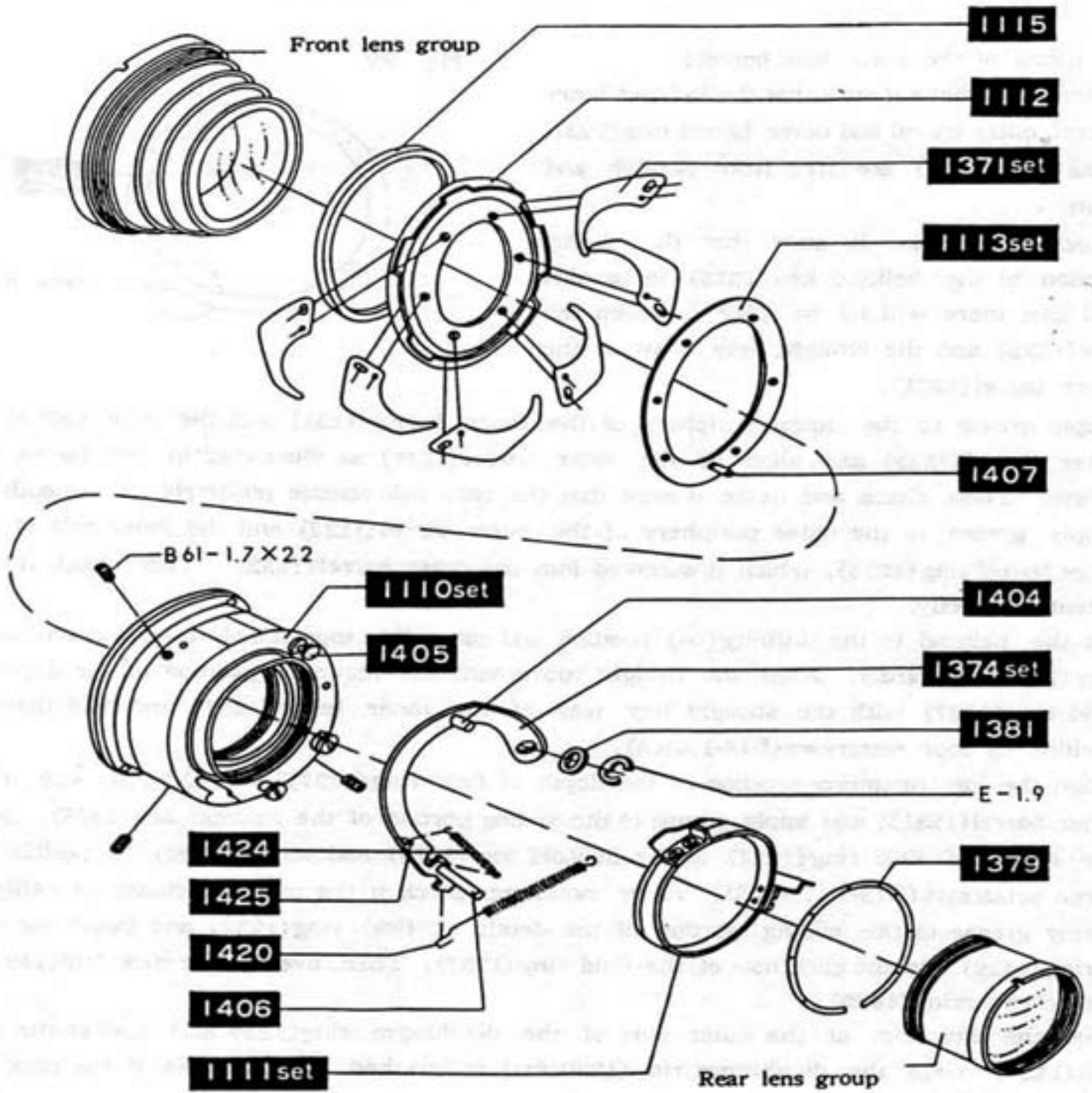
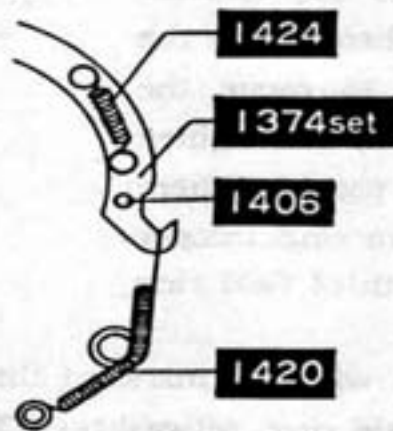

Fig. 98



N. Assembly of Outer lens barrel

Check points of the outer lens barrel :

- * Check and make it sure that the helicoid inner barrel, outer barrel and outer barrel ring(1231, 1232 and 1233) are free from scratch and stain.
- * Check and make it sure that the sliding portion of the helicoid key(1375) is parallel and that there will be no play between the key(1375) and the straight key way of the inner barrel(1231).

Fig. 99

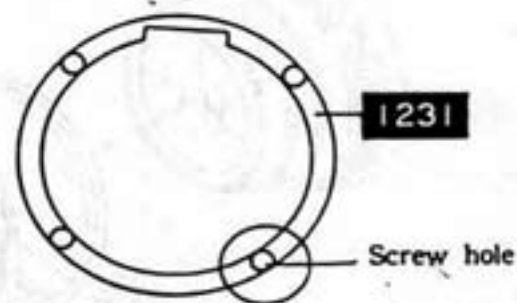

1. Apply grease to the outer periphery of the inner barrel(1231) and the inner side of the outer barrel(1232) and align of the inner barrel(1231) as illustrated in the figure and screw. Then, check and make it sure that the part will actuate positively and smoothly.
2. Apply grease to the outer periphery of the outer barrel(1232) and the inner side of the outer barrel ring(1233), which is screwed into the outer barrel(1232). Then check if they actuate correctly.
3. Set the helicoid to the infinity(∞) position and place the tapped hole of the outer barrel ring(1233) upwardly. Align the straight movement key mounting position of the depth of field ring(1237) with the straight key way of the inner barrel(1231) and hold them in position by four setscrews(B13-1.4 \times 5).
4. Align the key mounting position of the depth of field ring(1237) with the key way of the inner barrel(1231), and apply grease to the sliding portion of the helicoid key(1375). Place the depth of field ring(1237) to the helicoid key(1375) and secure them in position by three setscrews(B13-1.7 \times 3.5). After mounting, check if the moving actuate smoothly.
5. Apply grease to the sliding portion of the depth of field ring(1237) and insert the click spring(1429) into the click hole of the field ring(1237). Then, overlay the click ball(1427) on the click spring(1429).
6. Push the click slot of the inner side of the diaphragm ring(1239 set) against the click ball(1427) while the diaphragm ring(1239 set) is attached. Then, check if the click can actuate correctly.
7. Rotate the diaphragm ring(1239 set) and set to aperture scale of F1.4. Then, loosen the stopper setscrew(1432) so as to rotate the stopper pin(1408) (eccentric pin) and tighten the setscrew(1432) in such a position where the tip end of the diaphragm ring stopper (1387) abuts against the depth of field ring (1237).

Fig. 100

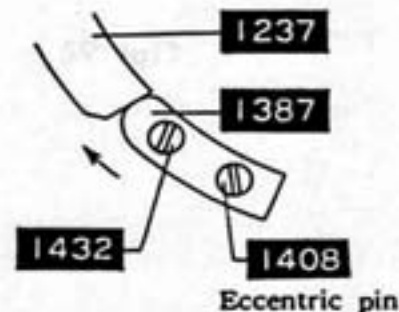

8. Align the distance scale(1236) with the mark of the helicoid inner barrel(1221) from the front side and attach the scale ring setwasher(1383) to three setscrews(B13-1.4 \times 3) respectively and then mount the distance scale(1236).

Fig. 101

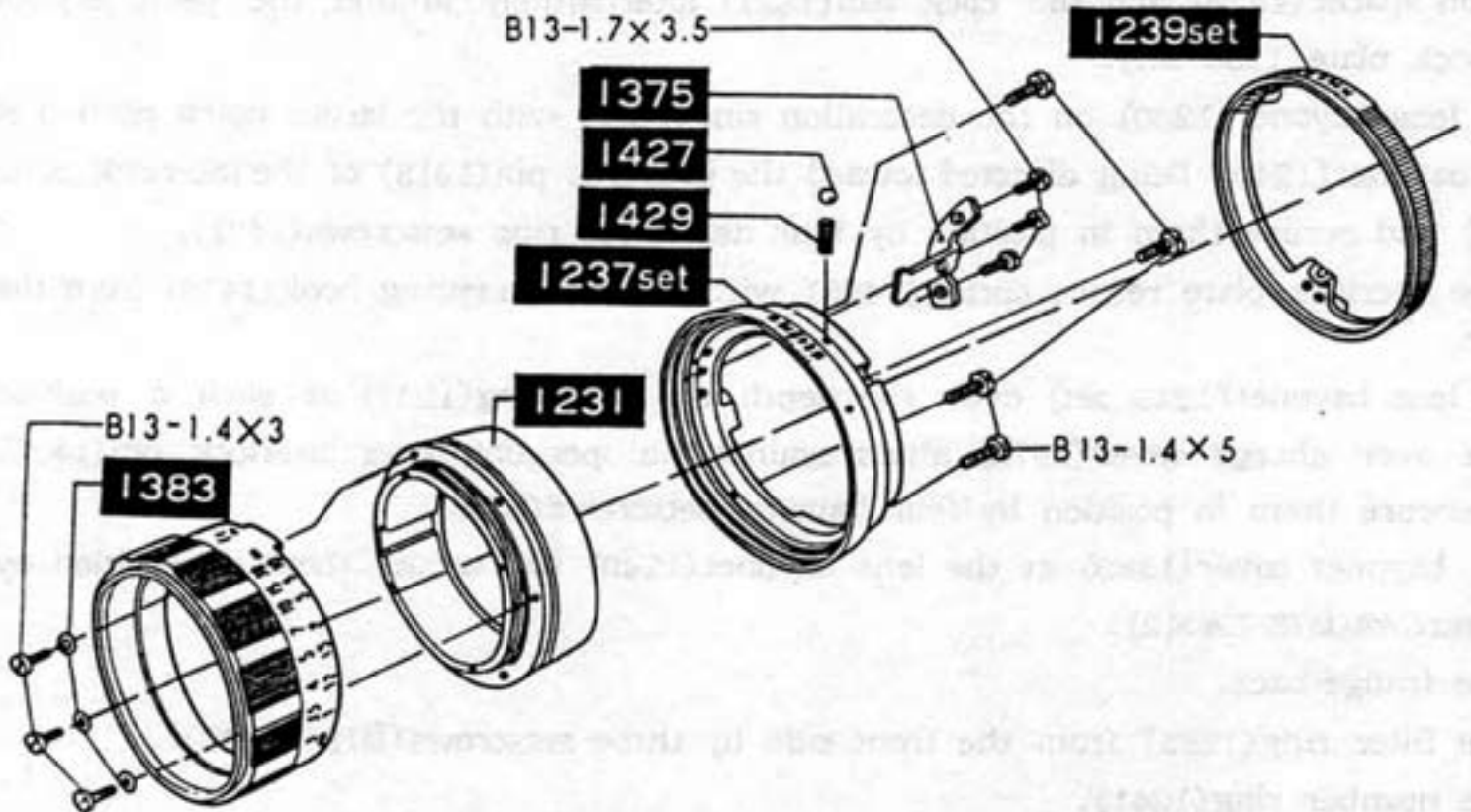
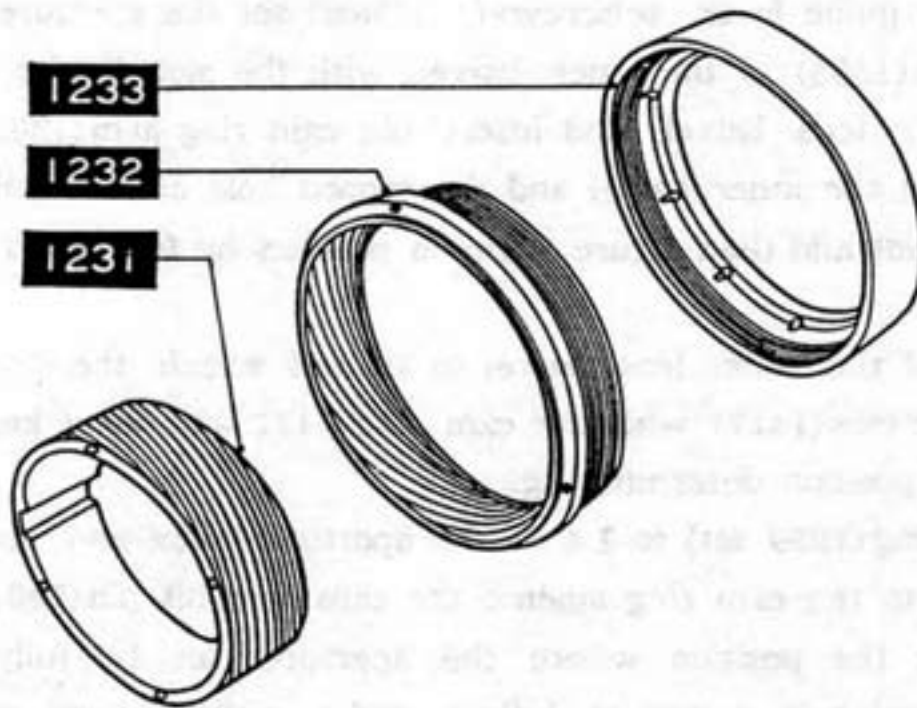

O. Assembly and mounting of Inner barrel and Outer lens barrel

1. Secure the inner barrel temporarily by two setscrews(B13-1.4x1.6) and contact the cam ring(1111 set) with the minimum diameter position determining jig. Secure temporarily the outer barrel by two guide lever setscrews(1417)and set the aperture scale to 16.
2. Align the cam ring arm(1385) of the inner barrel with the slot of the diaphragm guide lever(1376) of the outer lens barrel, and insert the cam ring arm(1385) into the guide lever(1376). Then align the inner barrel and the tapped hole of the helicoid inner barrel (1231) from the front side and then secure them in position by four inner barrel setscrews (1403).
3. Set the aperture scale of the outer lens barrel to 16 and attach the aperture index ring by two guide lever setscrews(1417) with the cam ring(1111 set) being kept to abut against the minimum diameter position determining jig.
4. Rotate the diaphragm ring(1239 set) to 1.4 of the aperture index and abut the fully open stopper(1386) attached to the cam ring against the cam ring hit pin(1404) of the arcuate lever in order to adjust the position where the aperture can be fully opened by the positions where the focusing is aimed at infinity and a rather short range respectively. Then, tighten by two setscrews(B13-1.4x1.6). Take out the minimum diameter position determining jig.
5. Attach the pre-set interlock plate(1238 set) to the helicoid decoration ring(1234) and place the rotation spacer(1426) and the click ball(1427) alternately around the periphery of the interlock plate(1238 set).
6. Place the lens bayonet(1240) on the decoration ring(1234) with the larger notch portion of the lens bayonet(1240) being directed toward the interlock pin(1413) of the interlock plate (1238 set) and secure them in position by four decoration ring setscrews(1431).
7. Engage the interlock plate return spring(1422) with the return spring hook(1419) from the front side.
8. Place the lens bayonet(1240 set) over the depth of field ring(1237) at such a position where the over charge lever(1373) abuts against the operation lever interlock pin(1406) and then secure them in position by four bayonet setscrews(1430).
9. Place the bayonet cover(1380) at the lens bayonet(1240) and secure them in position by three setscrews(B73-1.4x2).
10. Adjust the frange-back.
11. Mount the filter ring(1235) from the front side by three setscrews(B13-1.4x3).
12. Mount the number ring(1241).

Fig. 102

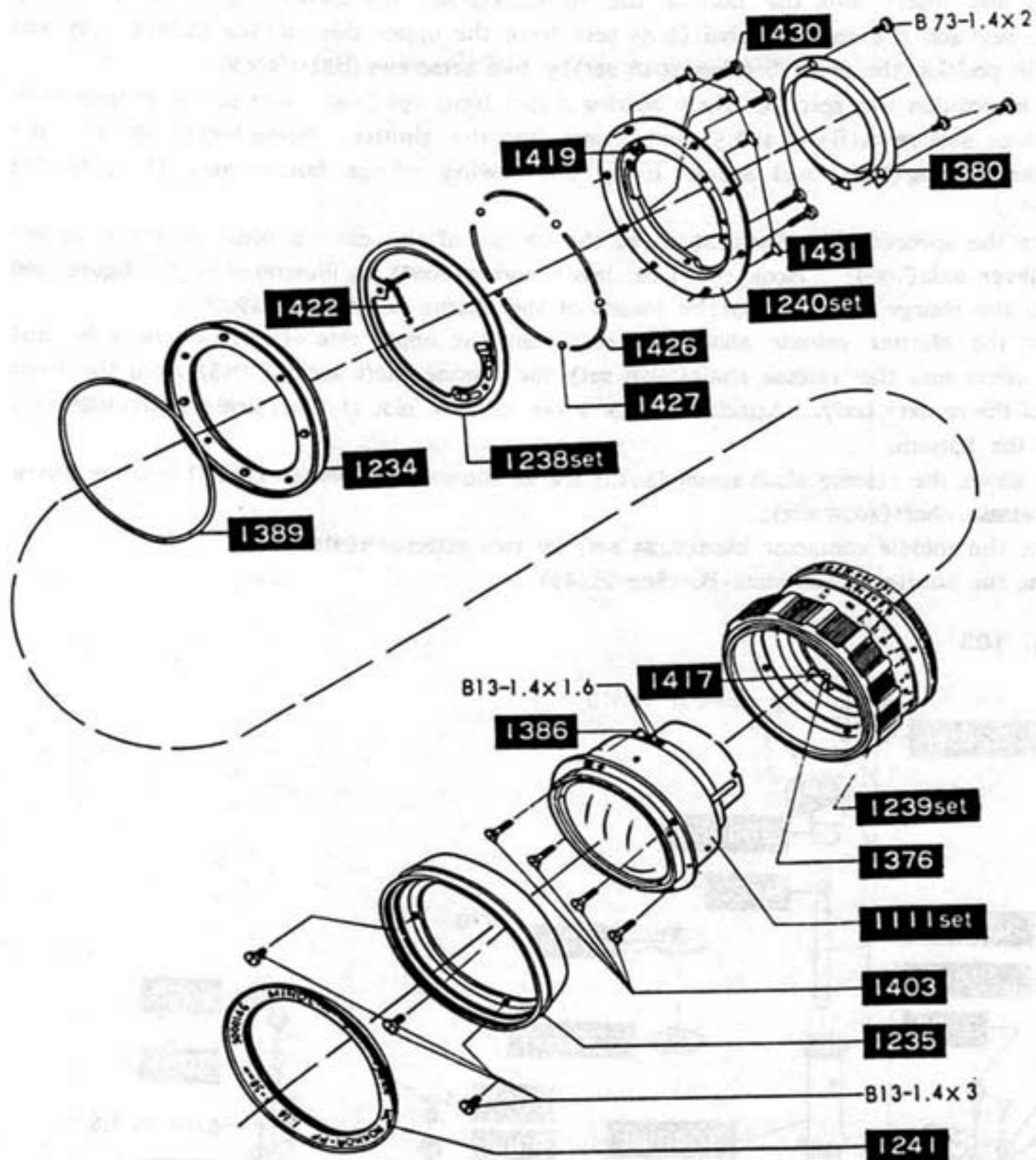

P. Mounting of Sprocket

1. Align with and fit into the slot of the sprocket gear shaft bearing(3048 set) the clutch pin (9123) of the sprocket shaft(3049 set). Mount the sprocket(3046) as indicated in the figure and insert into the hole of the sprocket(3046) the sprocket gear shaft bearing (3048 set) and the sprocket shaft(3049 set) from the upper side of the camera body and hold in position the shaft bearing(3048 set) by two setscrews(B31-1.4×3).
2. Hold in position the sprocket shaft bearing(3050) from the lower side of the camera body by three setscrews(B31-1.4x2.5) and insert into the shutter release lever(3059 set) the sprocket spring(3051) and secure it by the rewind release button(3053) (Left handed screw).
3. Secure the sprocket lock lever(3066) to the bottom of the camera body by means of the lock lever axis(9004). Hook the lock lever spring(3067) as illustrated in the figure and attach the charge lever-A(3061) by means of the charge lever-A axis(9006).
4. Insert the shutter release shaft(3028 set) from the upper side of the camera body, and then insert into the release shaft(3028 set) the release shaft spring(3043) from the front side of the camera body. Attach the lock lever into the slot of the release shaft(3028 set) from the bottom.
5. Push down the release shaft spring(3043) and fit the coupling washer(E-1.5) into the slot of the release shaft(3028 set).
6. Mount the middle contactor base(2224 set) by two setscrews(9103).
7. Mount the shutter base plate-B. (See P. 49)

Fig. 103

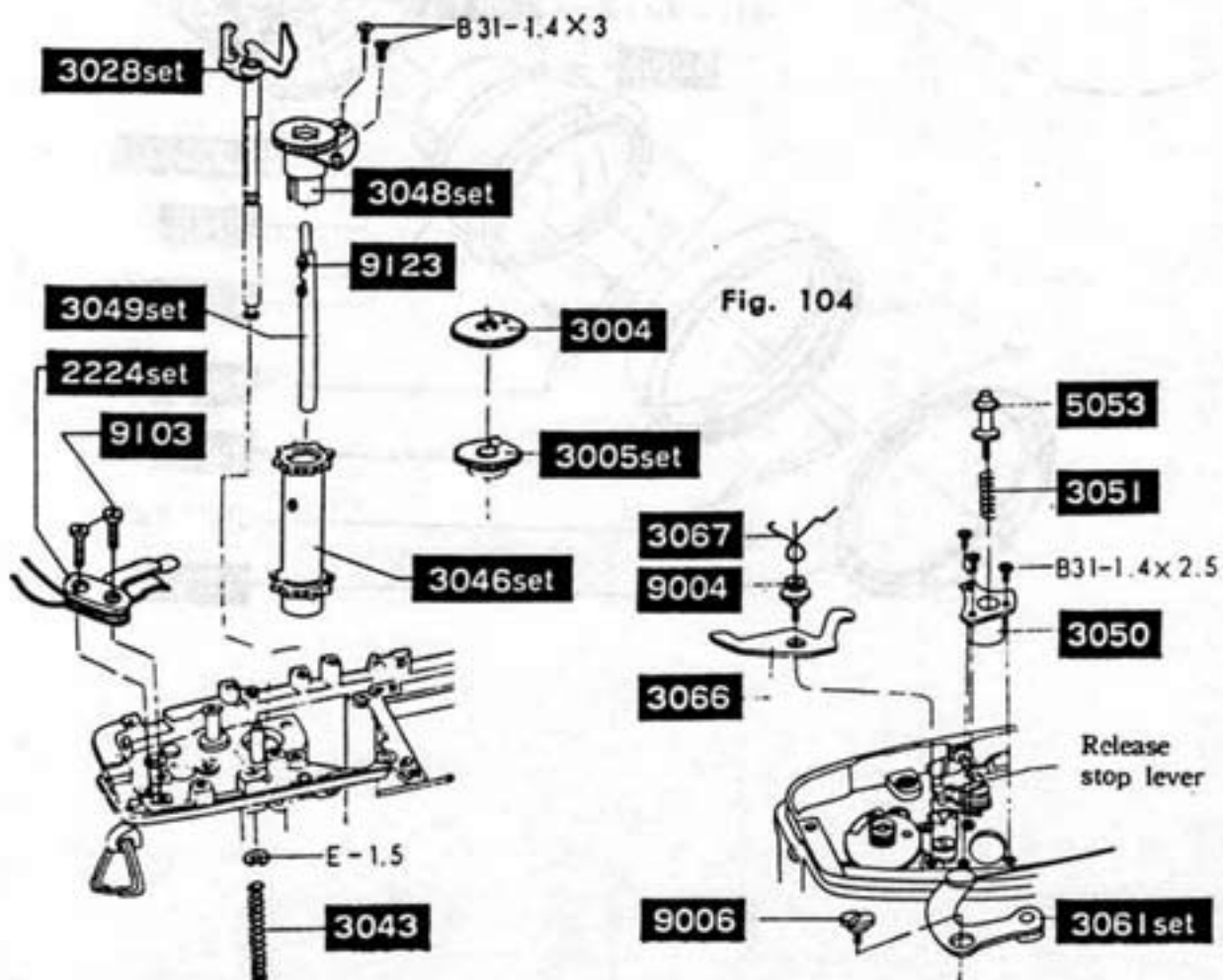

CROSS SECTION OF SRT₁₀₁

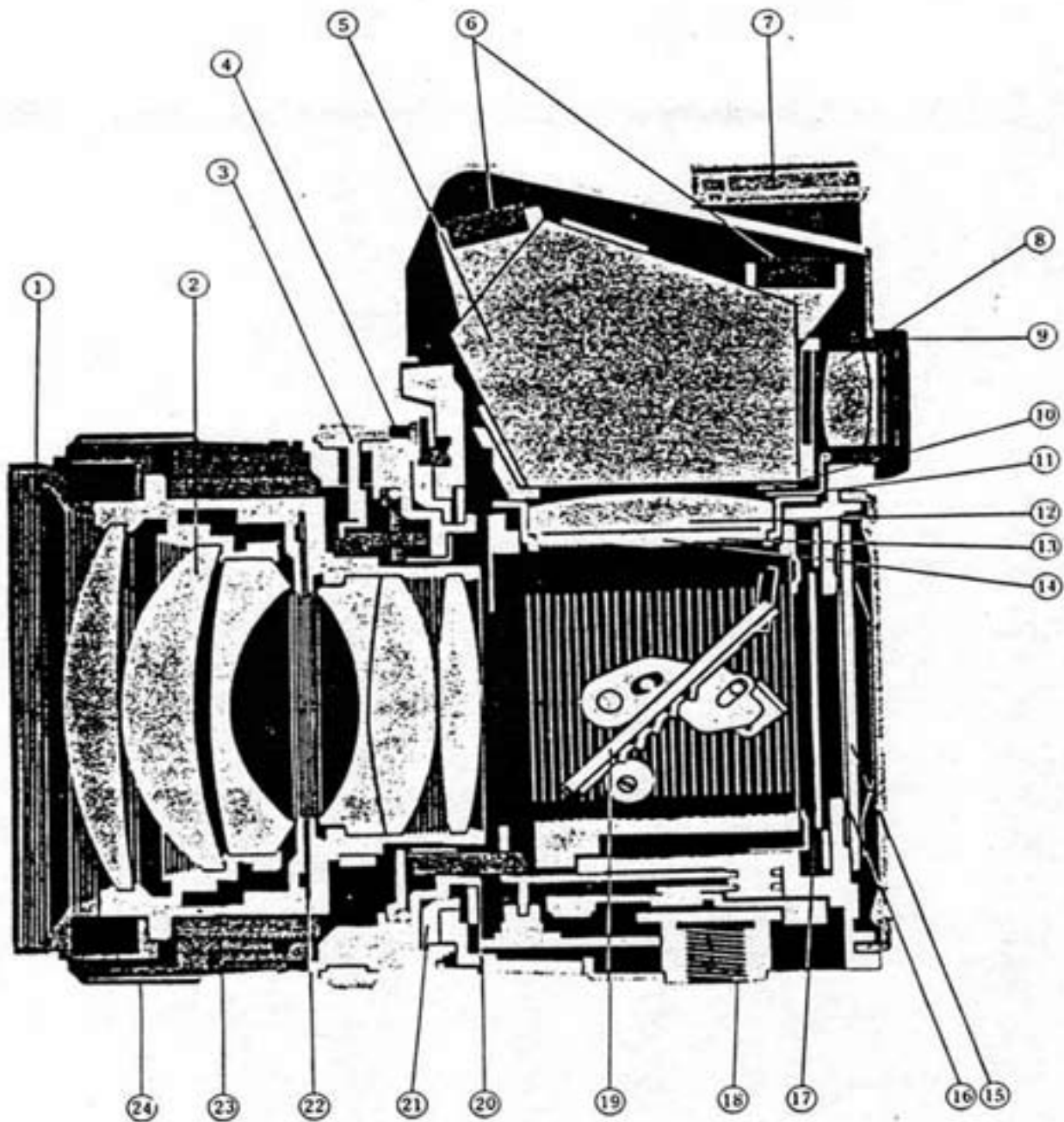

- | | | |
|--|-----------------------------|----------------------|
| ① Filter ring | ⑨ Eyepiece holder | ⑰ Shutter curtain |
| ② Standard lens | ⑩ Shutter speed scale plate | ⑱ Tripod socket |
| ③ Diaphragm ring | ⑪ Shutter speed needle | ⑲ Auto pre-set pin |
| ④ Meter coupler | ⑫ Condenser lens | ⑳ Lens bayonet mount |
| ⑤ Pentagon prism | ⑬ Fresnel lens | ㉑ Lens mount |
| ⑥ Light meter photo-cell
(Cds photo-cell) | ⑭ Fine micro prism | ㉒ Diaphragm blade |
| ⑦ Accessories clip | ⑮ Film pressure plate | ㉓ Lens helicoid |
| ⑧ Eyepiece lens | ⑯ Film | ㉔ Focusing ring |

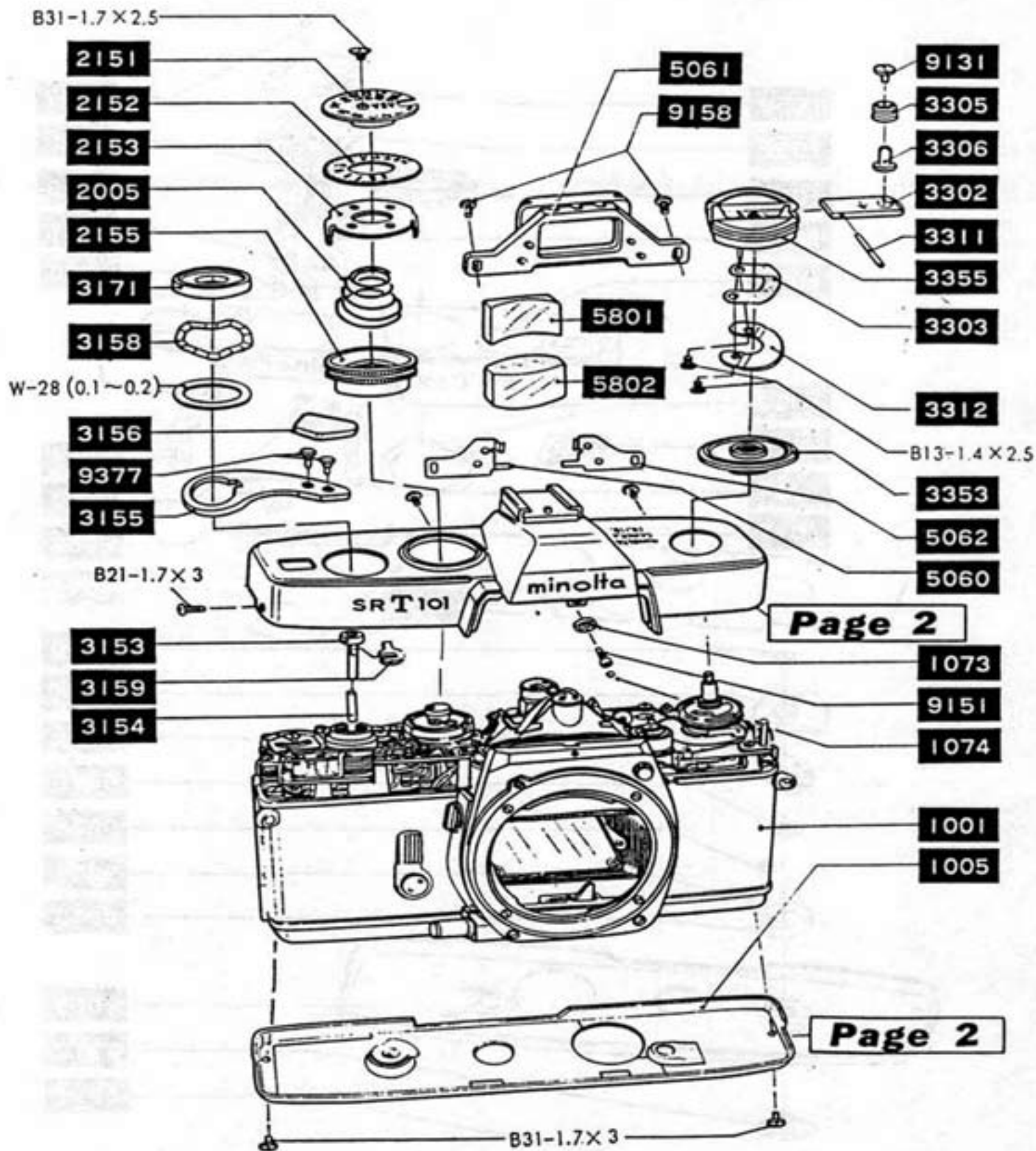

Complete set Parts.

Key number 代表部品番号	Including parts number 結合部品番号
2152-71	2152, 2153.
3155-71	3155, 3156, 9377.
3302-71	3302, 3306, 3311.
5061-71	5061, 5060, 5062, 5801, 5802.

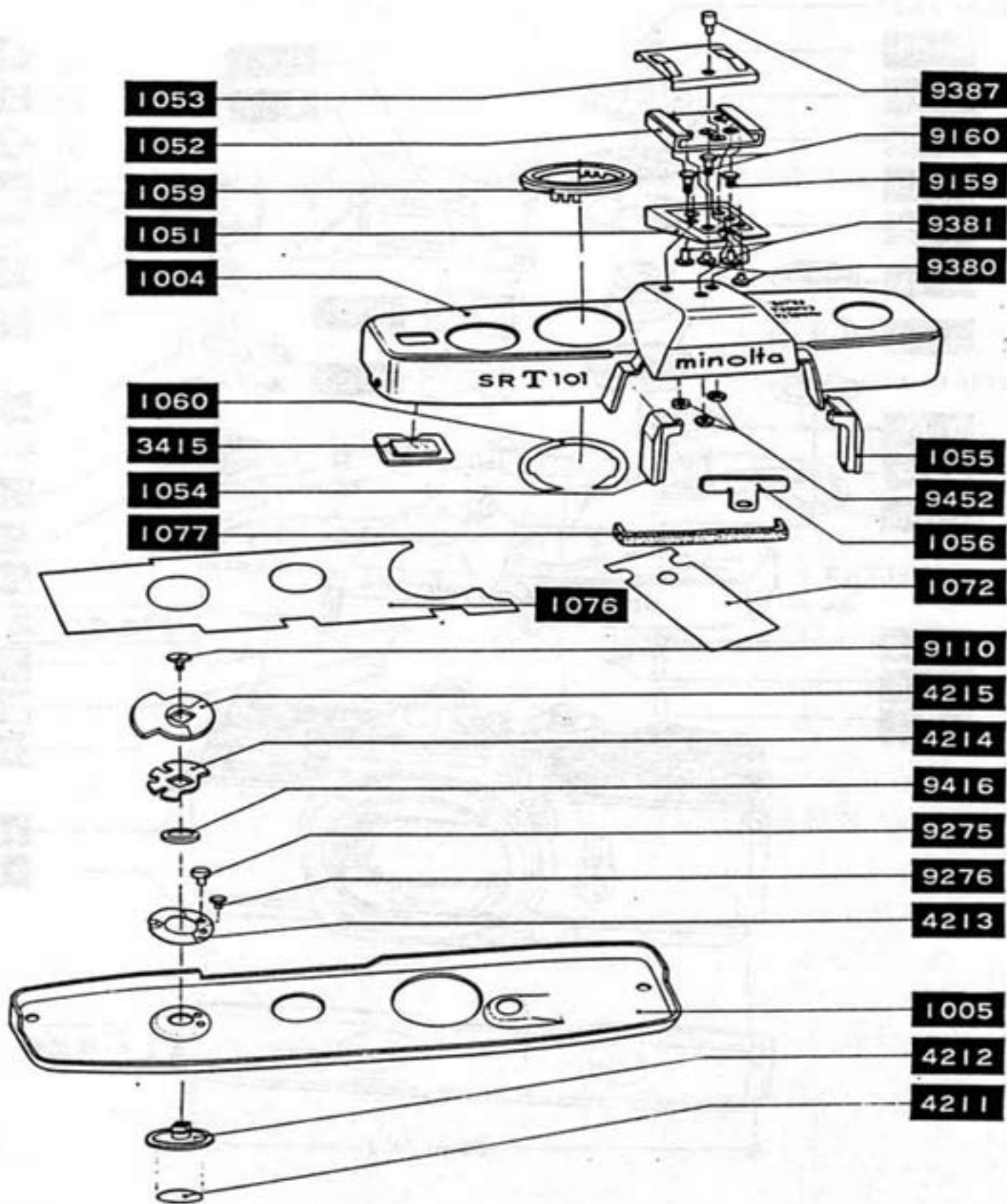

Complete set parts.

Key number 代表部品番号	Including parts number 結合部品番号
1004-71	1004, 1054, 1055, 1056, 1059, 1060, 3415.
1005-71	1005, 4213, 9275, 9276.
1052-71	1052, 1051, 1053, 9159, 9160, 9380,

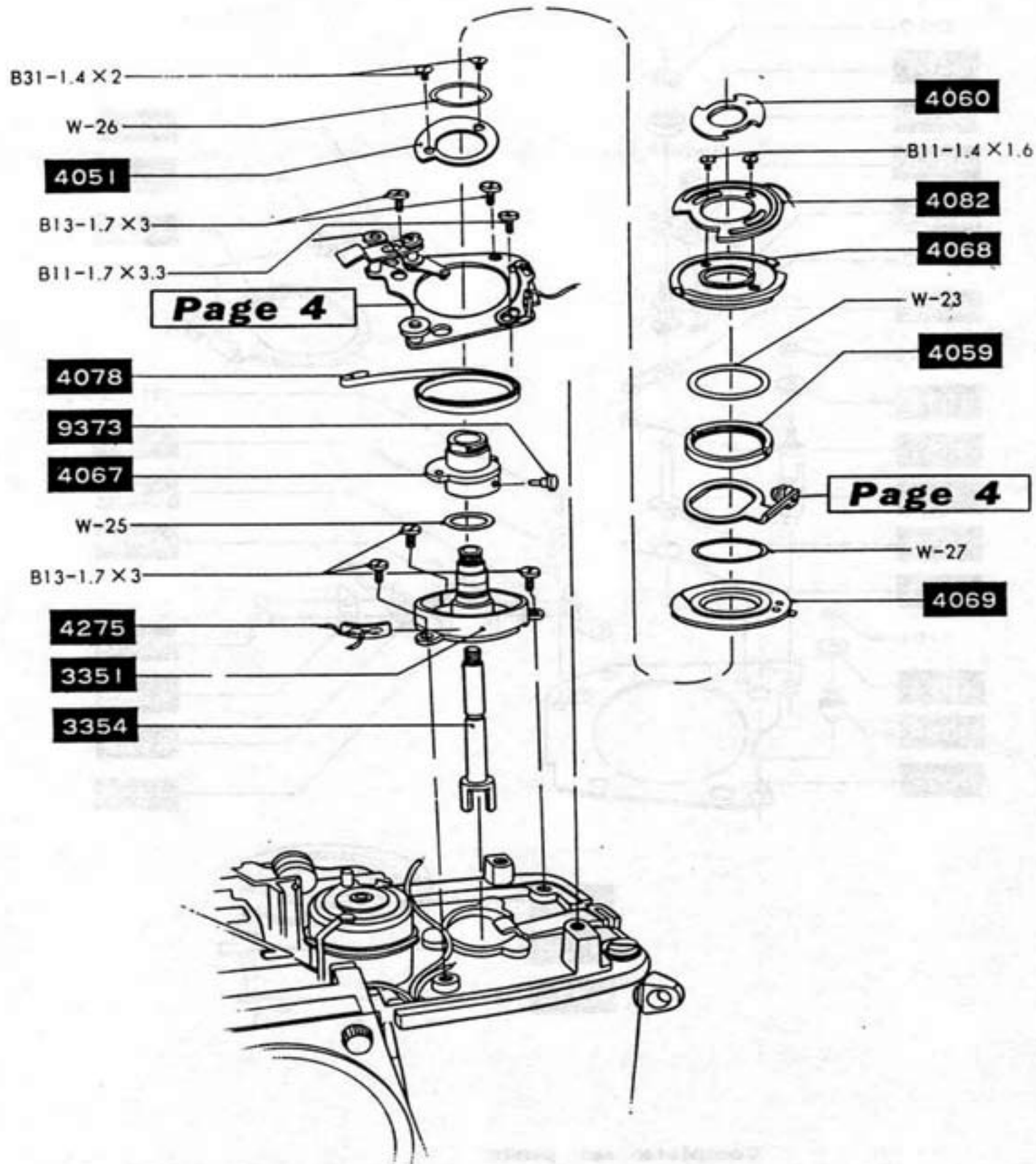

Complete set Parts.

Key number 代表部品番号	Including parts number 結合部品番号
4067-71	4067, 9373.

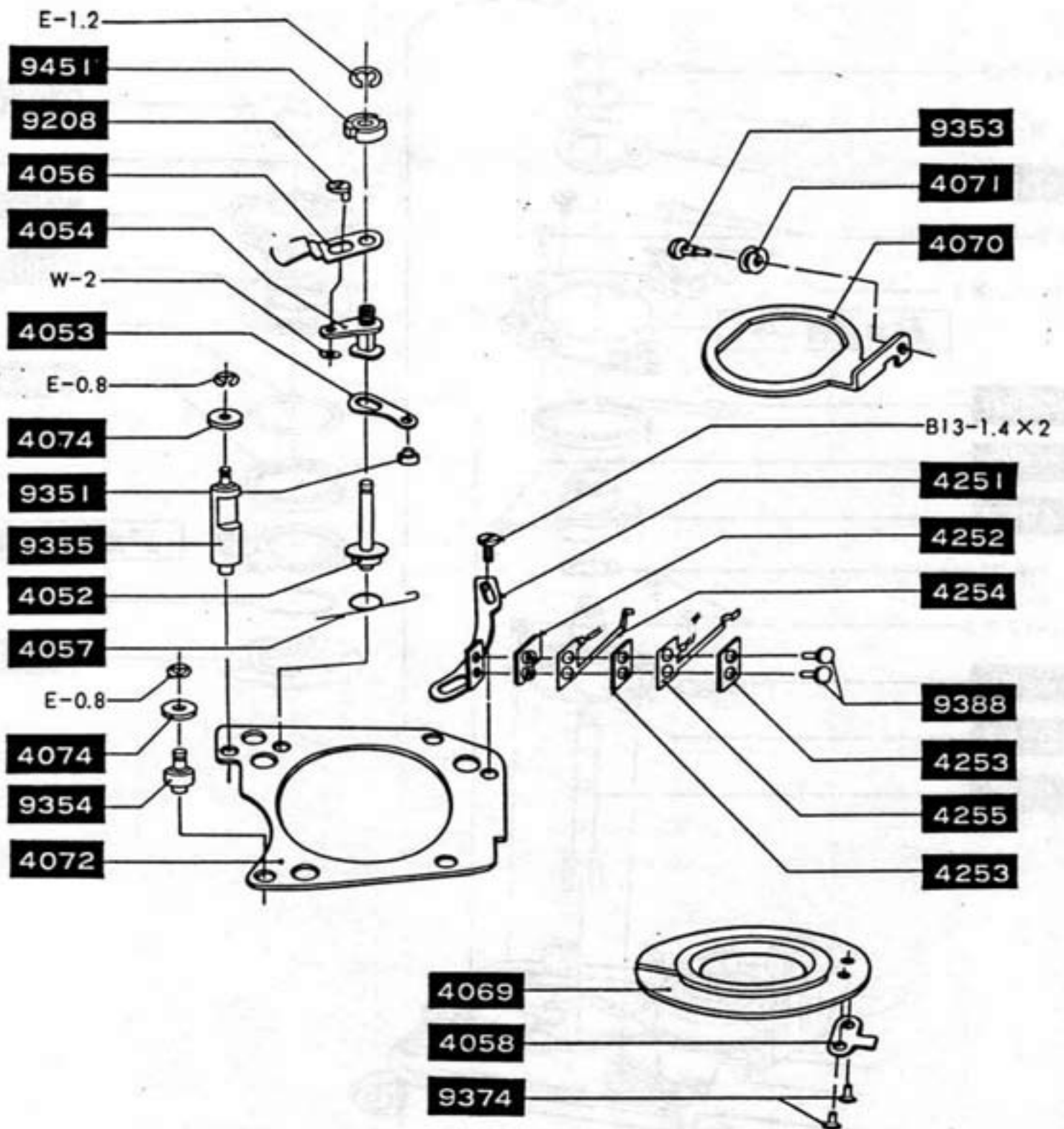

Complete set parts

Key number 代表部品番号	Including parts number 結合部品番号
4054-71	4054, 4053, 9208, 9351, W-2.
4069-71	4069, 4058, 9374.
4070-71	4070, 4071, 9353.
4072-71	4072, 4052, 9354, 9355.
4251-71	4251, 4252, 4253, 4254, 4255, 9388.

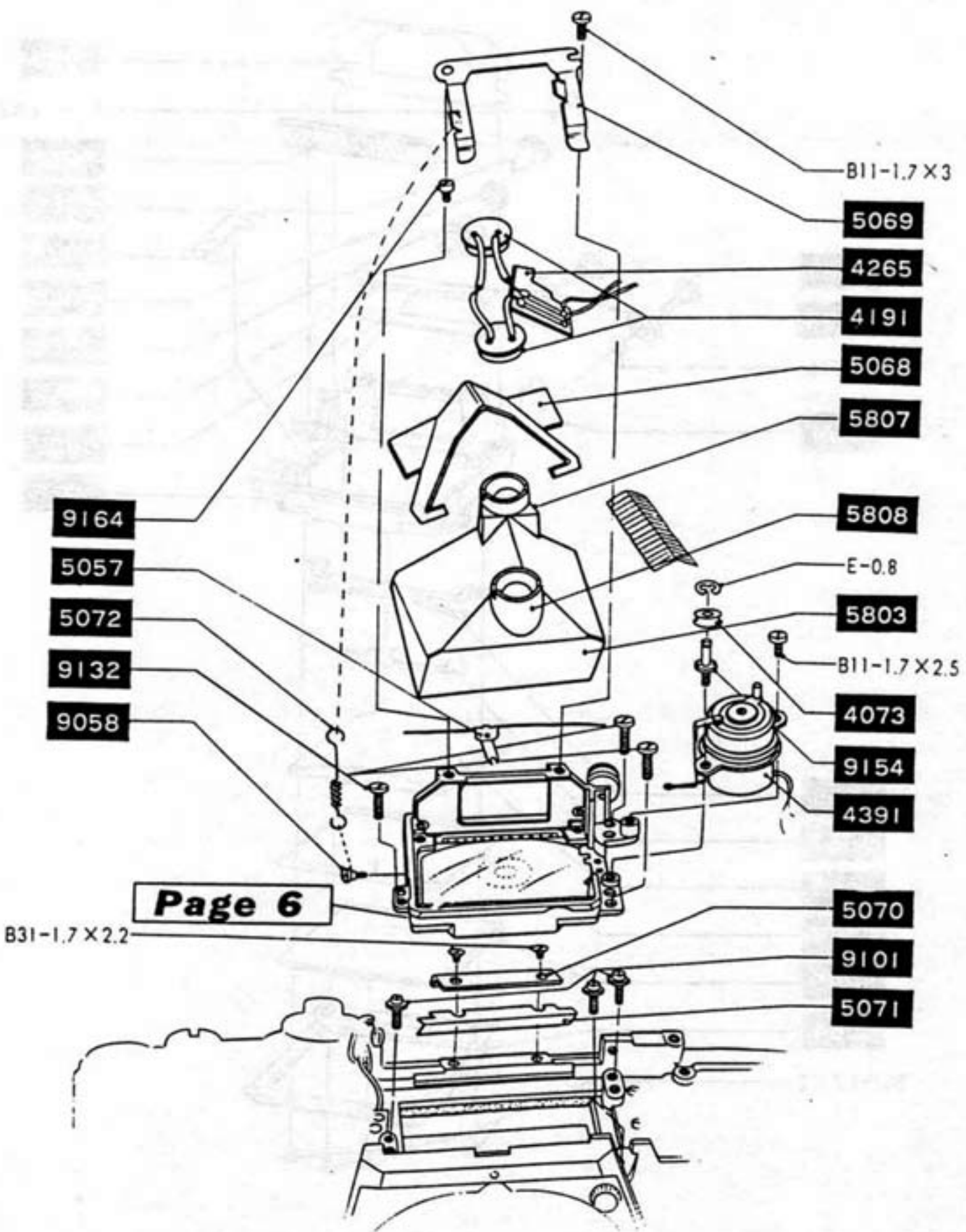

Page 6

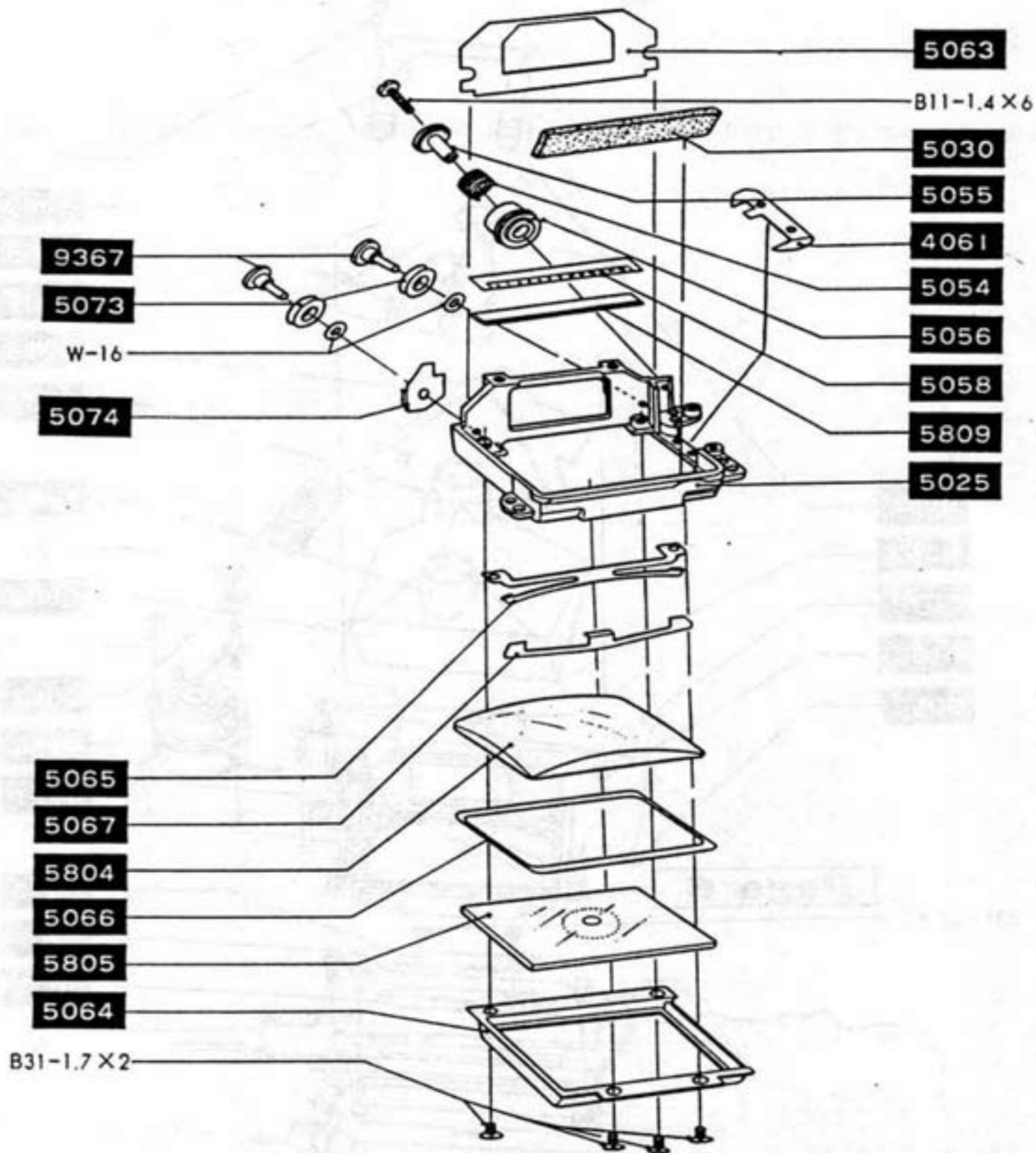

Complete set parts.

Key number 代表部品番号	Including parts number 結合部品番号
5025-71	5025, 5030, 5073, 5074, 9367, W-16.

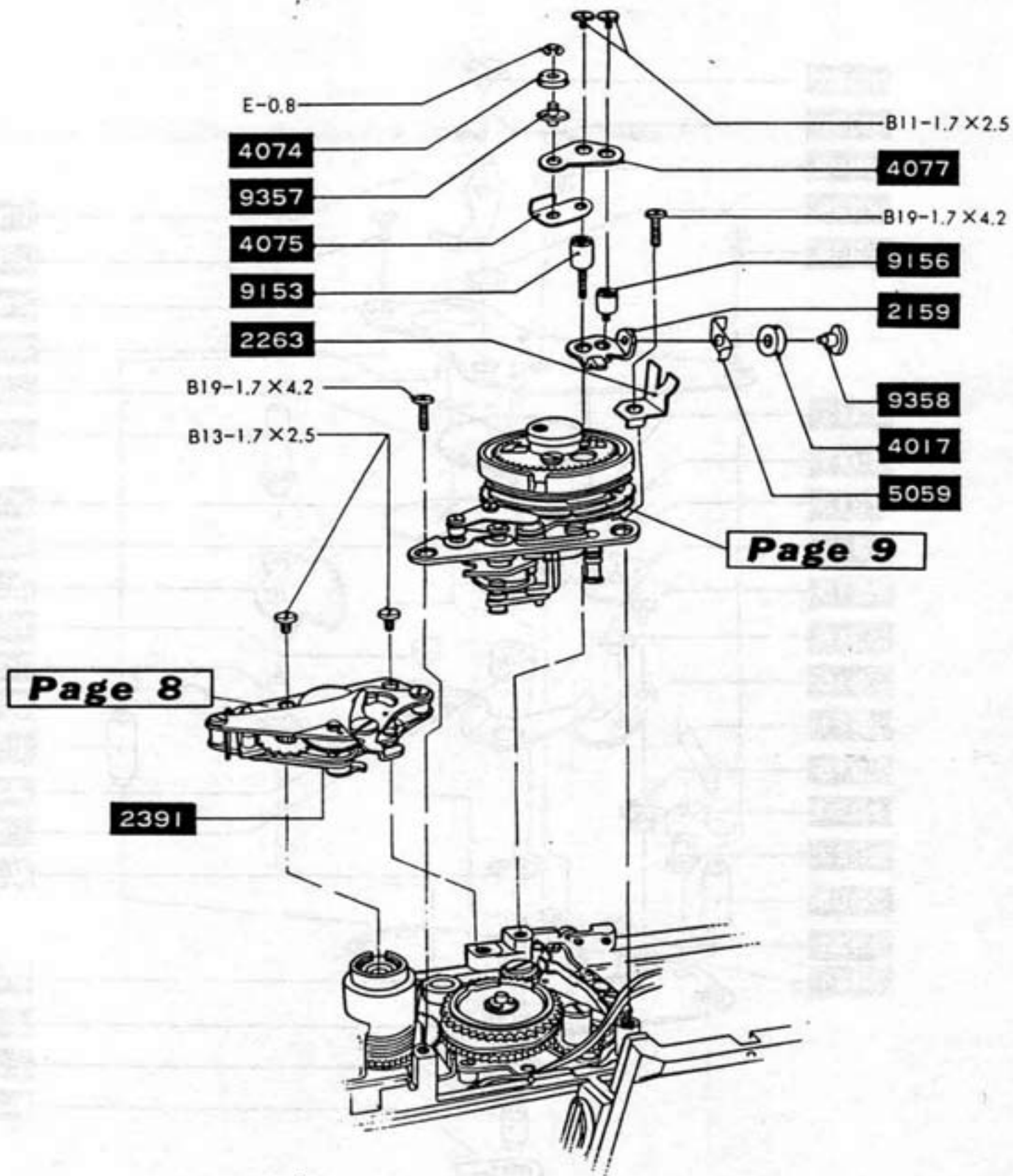

Complete set Parts.

Key number 代表部品番号	Including parts number 結合部品番号
2159-71	2159, 4017, 5059, 9358.
4077-71	4077, 4075, 9357.

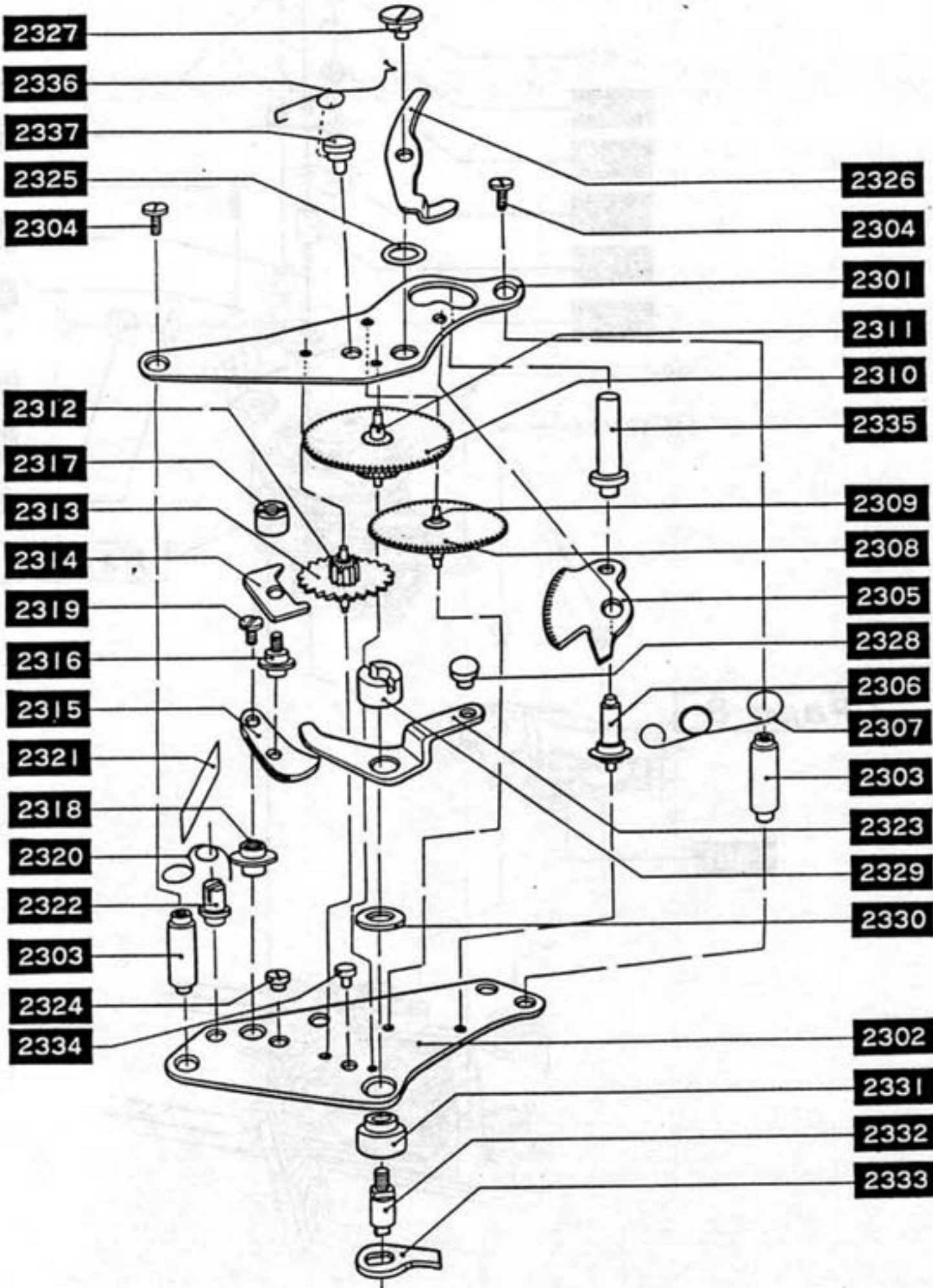

2327

2336

2337

2325

2304

2312

2317

2313

2314

2319

2316

2315

2321

2318

2320

2322

2303

2324

2334

2326

2304

2301

2311

2310

2335

2309

2308

2305

2328

2306

2307

2303

2323

2329

2330

2302

2331

2332

2333

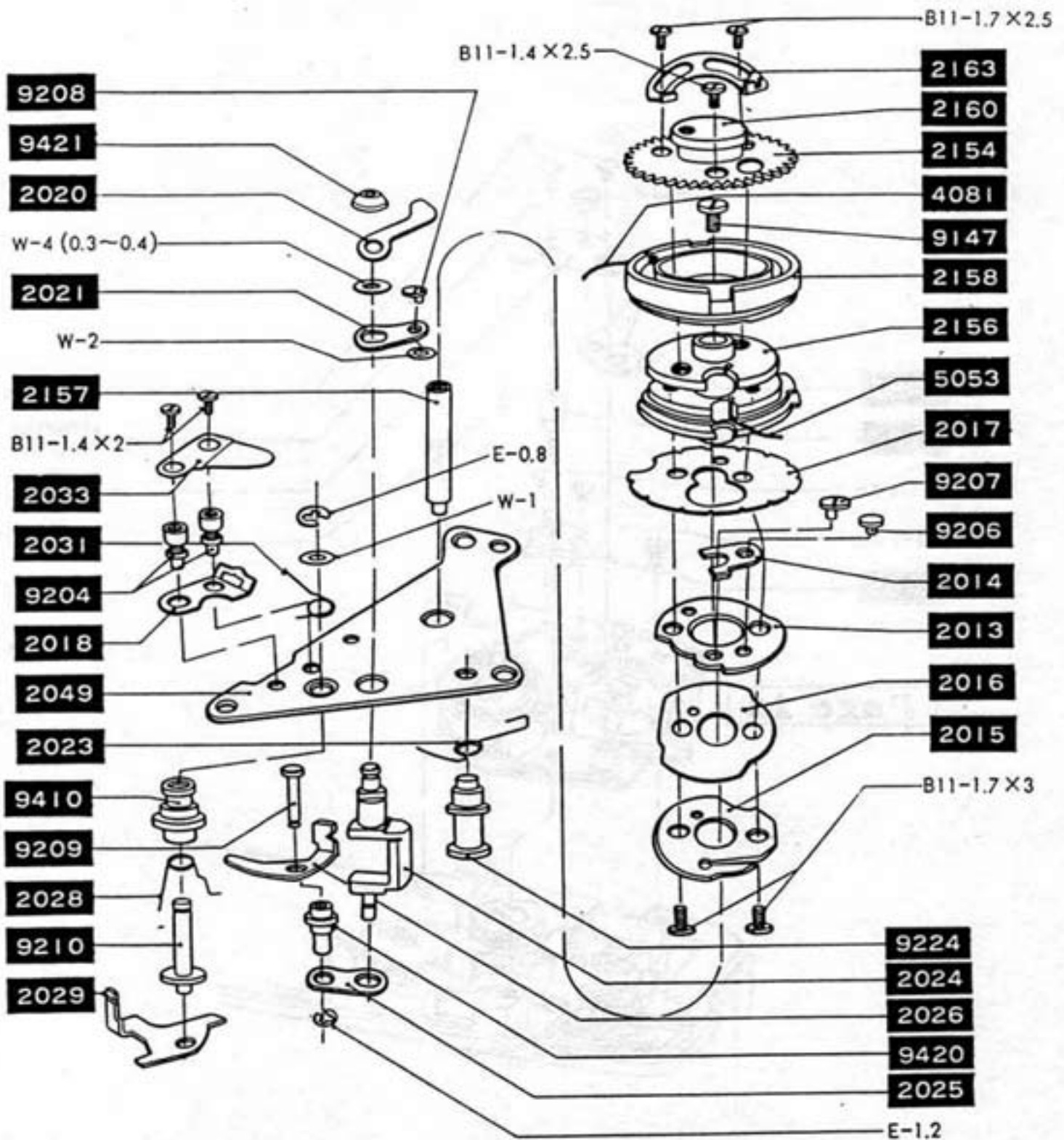

Complete set parts.

Key number 代表部品番号	Including parts number 結合部品番号
2013-71	2013, 2014, 9206, 9207.
2021-71	2021, 9208, W-2.
2024-71	2024, 2025, 2026, 9420.
2029-71	2029, 9210.
2049-71	2049, 2018, 2157, 9204, 9224, 9410.
2154-71	2154, 2160.

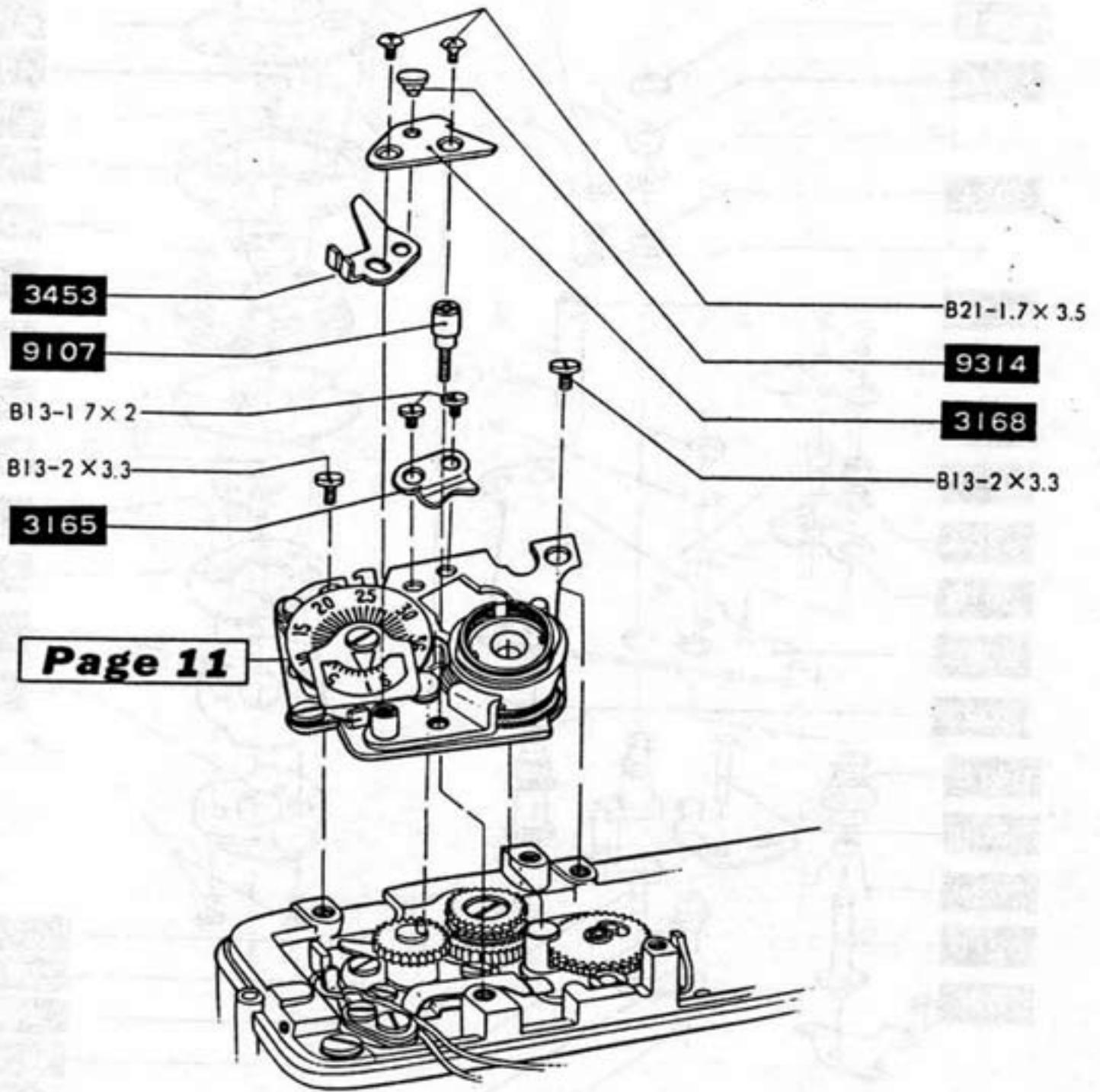

Complete set parts.

Key number 代表部品番号	Including parts number 結合部品番号
3168-71	3168, 3453, 9314.

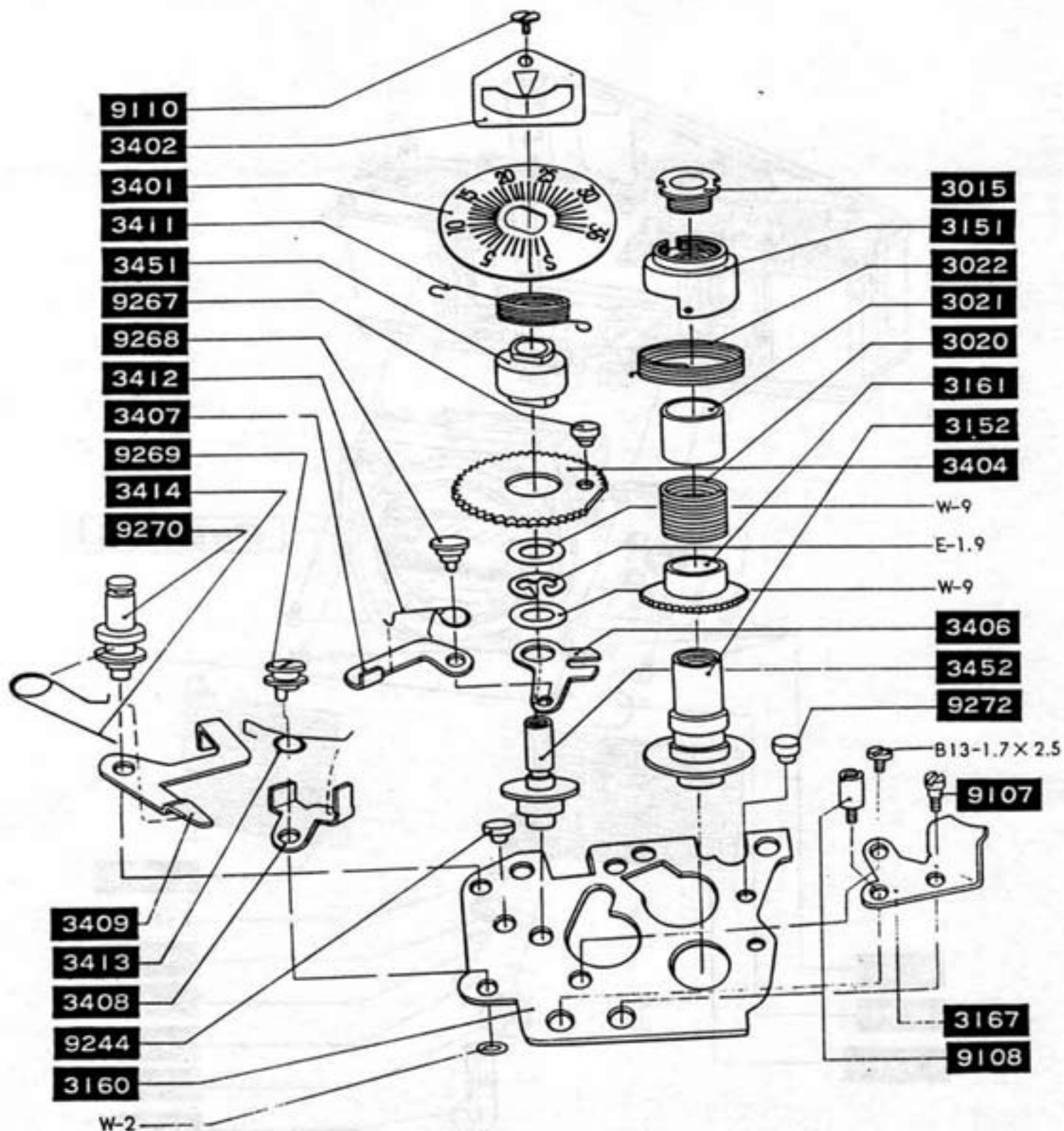

Complete set parts.

Key number 代表部品番号	Including parts number 結合部品番号
3160-71	3160, 3152, 3408, 3409, 3452, 9244, 9269, 9270, 9272, W-2.
3401-71	3401, 3404, 3411, 3451, 9267.
3406-71	3406, 3407, 9268.

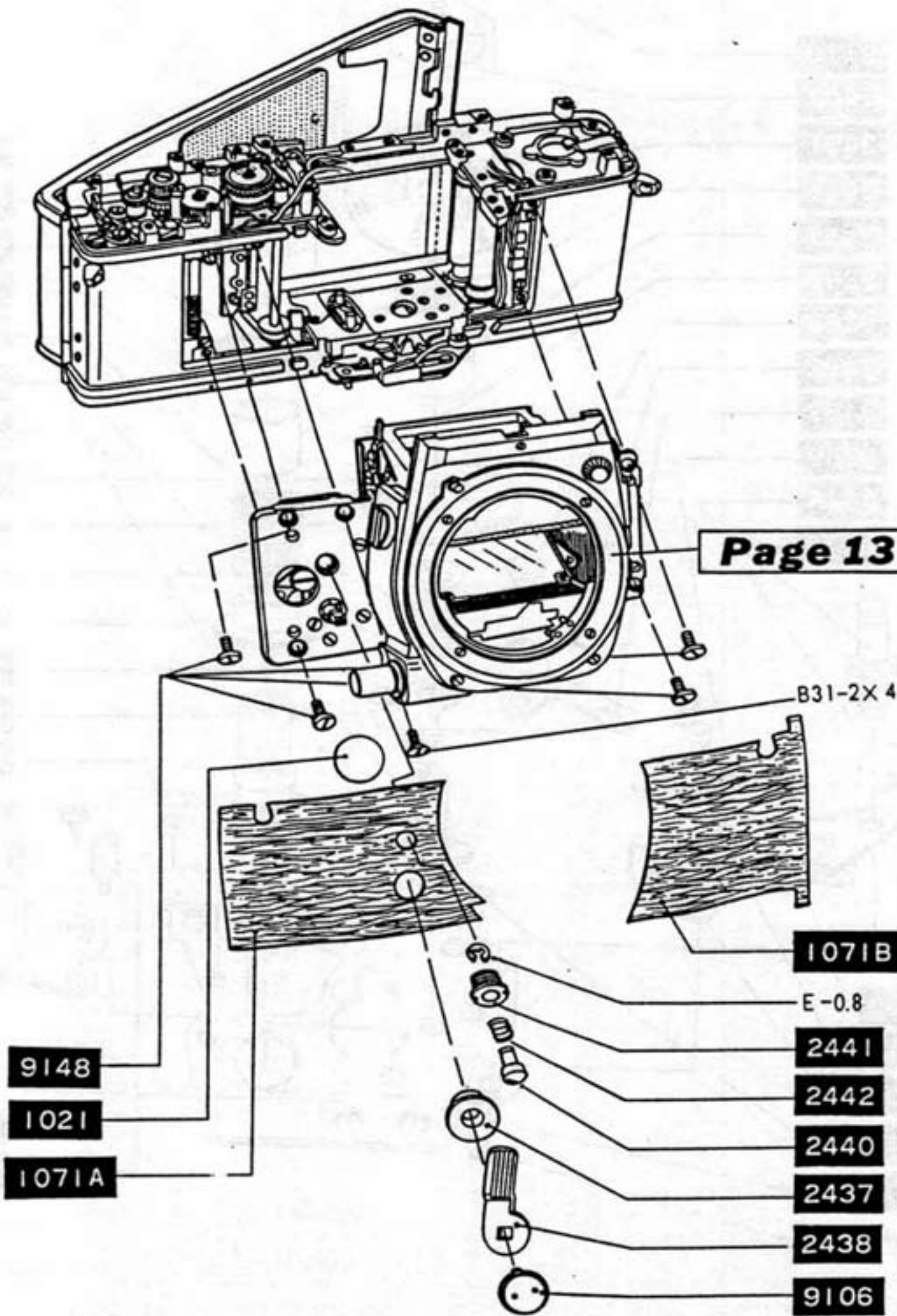

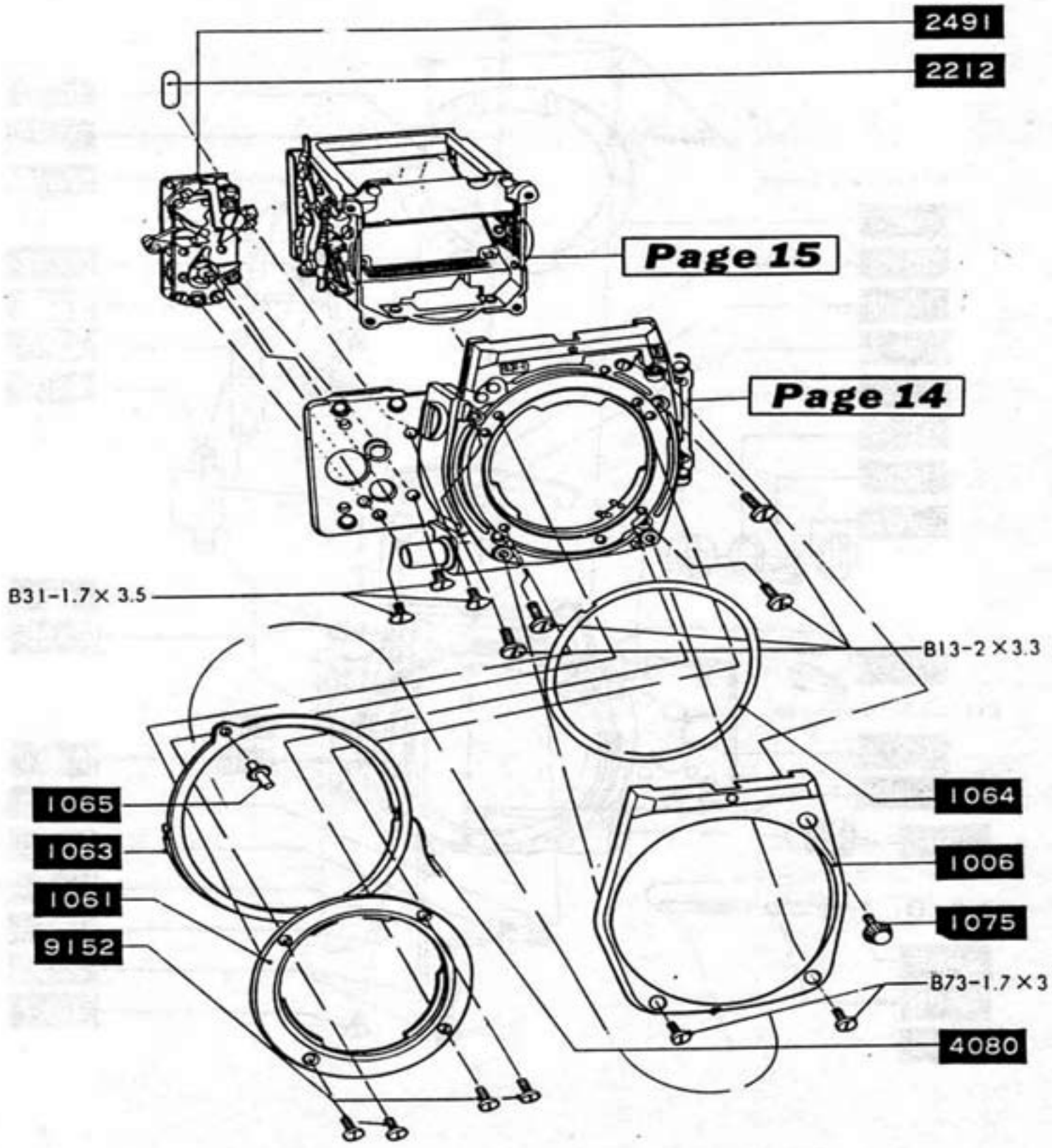

Complete set parts.

Key number 代表部品番号	Including parts number 結合部品番号
1063-71	1063, 1065.

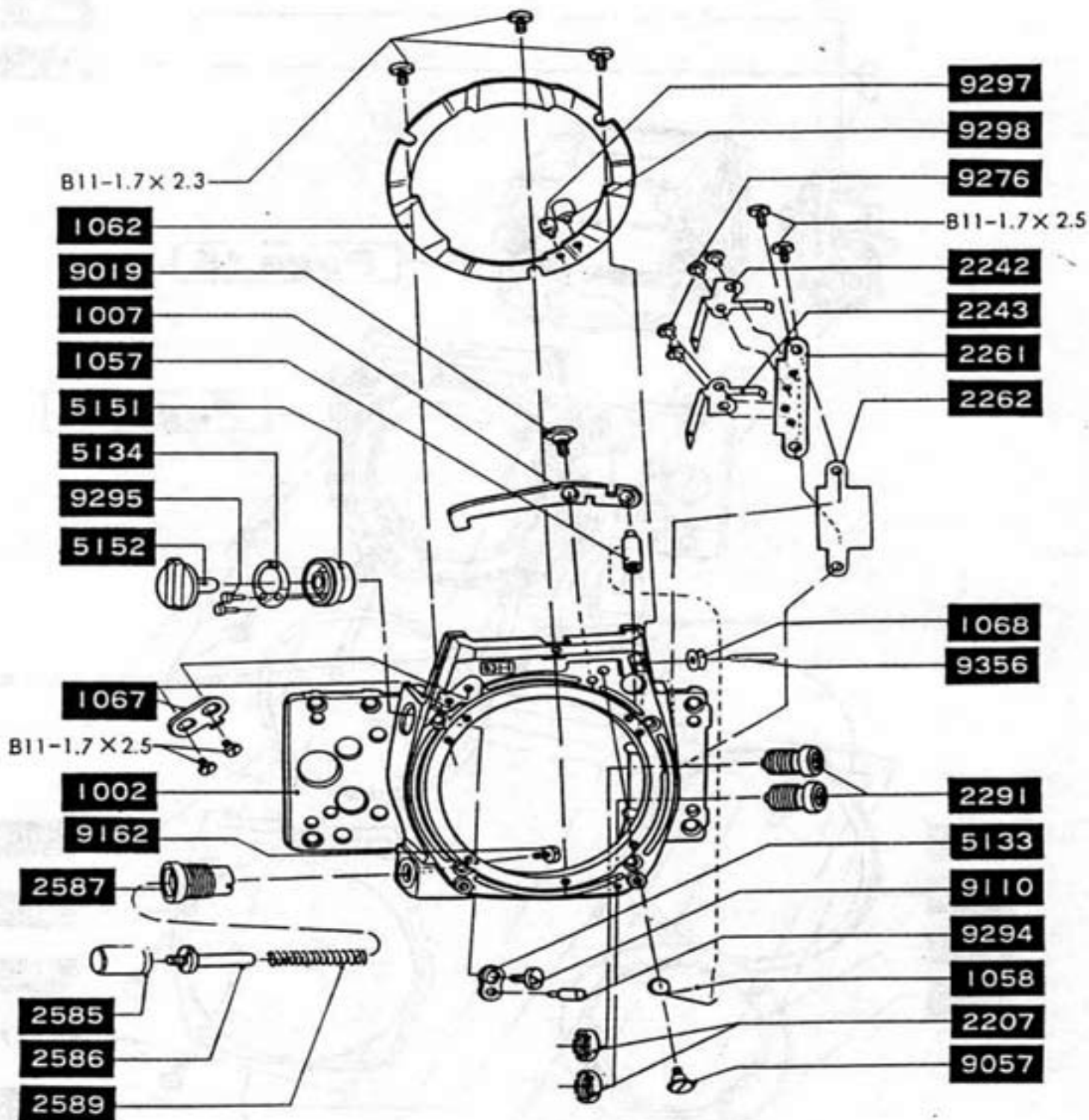

Complete set parts.

Key number 代表部品番号	Including parts number 結合部品番号
1002-71	1002, 5134, 5151, 9295.
1007-71	1007, 1057.
1062-71	1062, 9297, 9298.
2261-71	2261, 2242, 2243, 2262, 9276.
5133-71	5133, 9294.

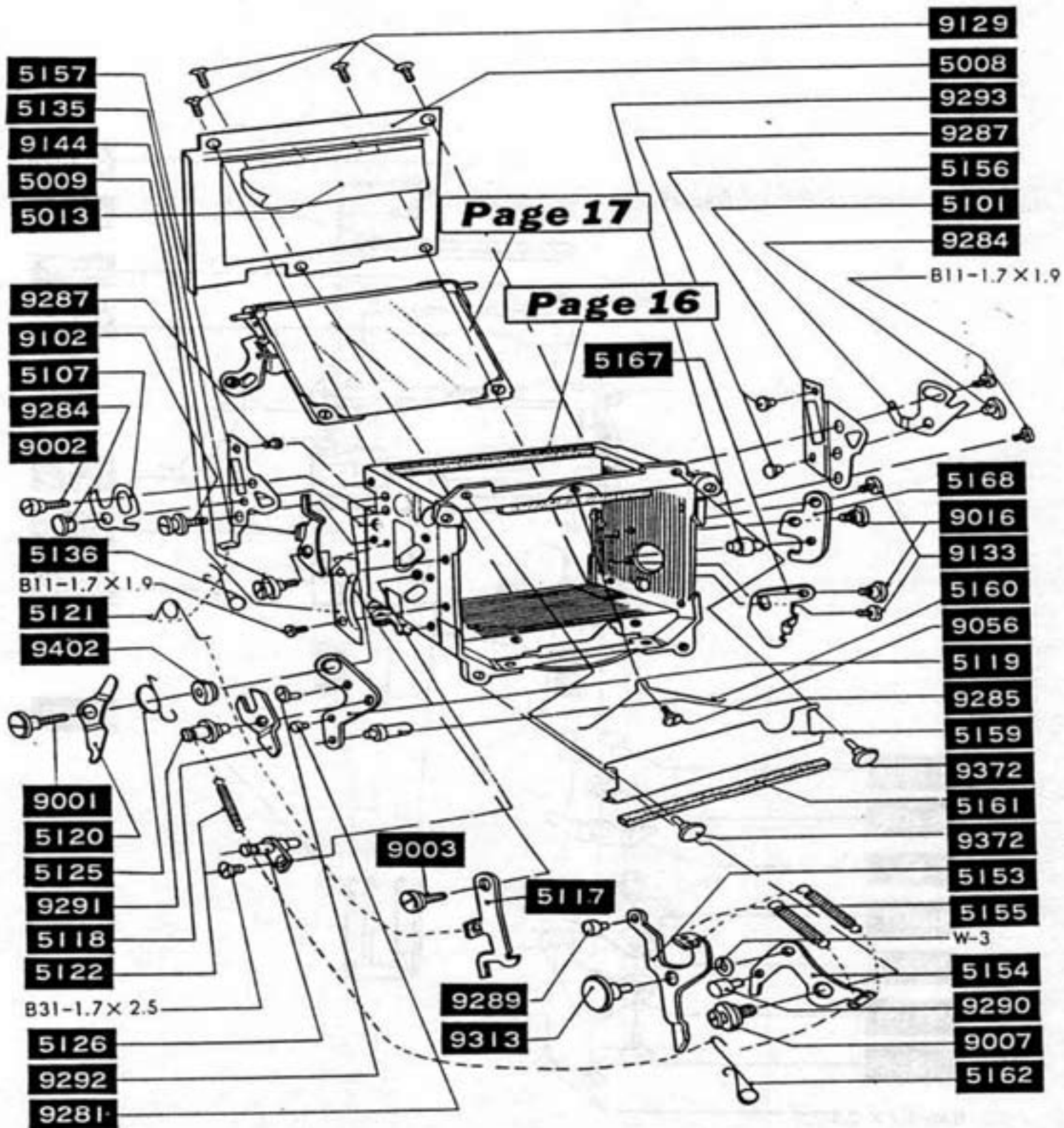

Complete set parts.

Key number 代表部品番号	Including parts number 結合部品番号
5008-71	5008, 5013.
5119-71	5119, 5118, 9281, 9285, 9291.
5153-71	5153, 5154, 9289, 9290, 9313, W-3.
5156-71	5156, 5101, 9284, 9287.
5157-71	5157, 5107, 9284, 9287.
5168-71	5168, 9293.

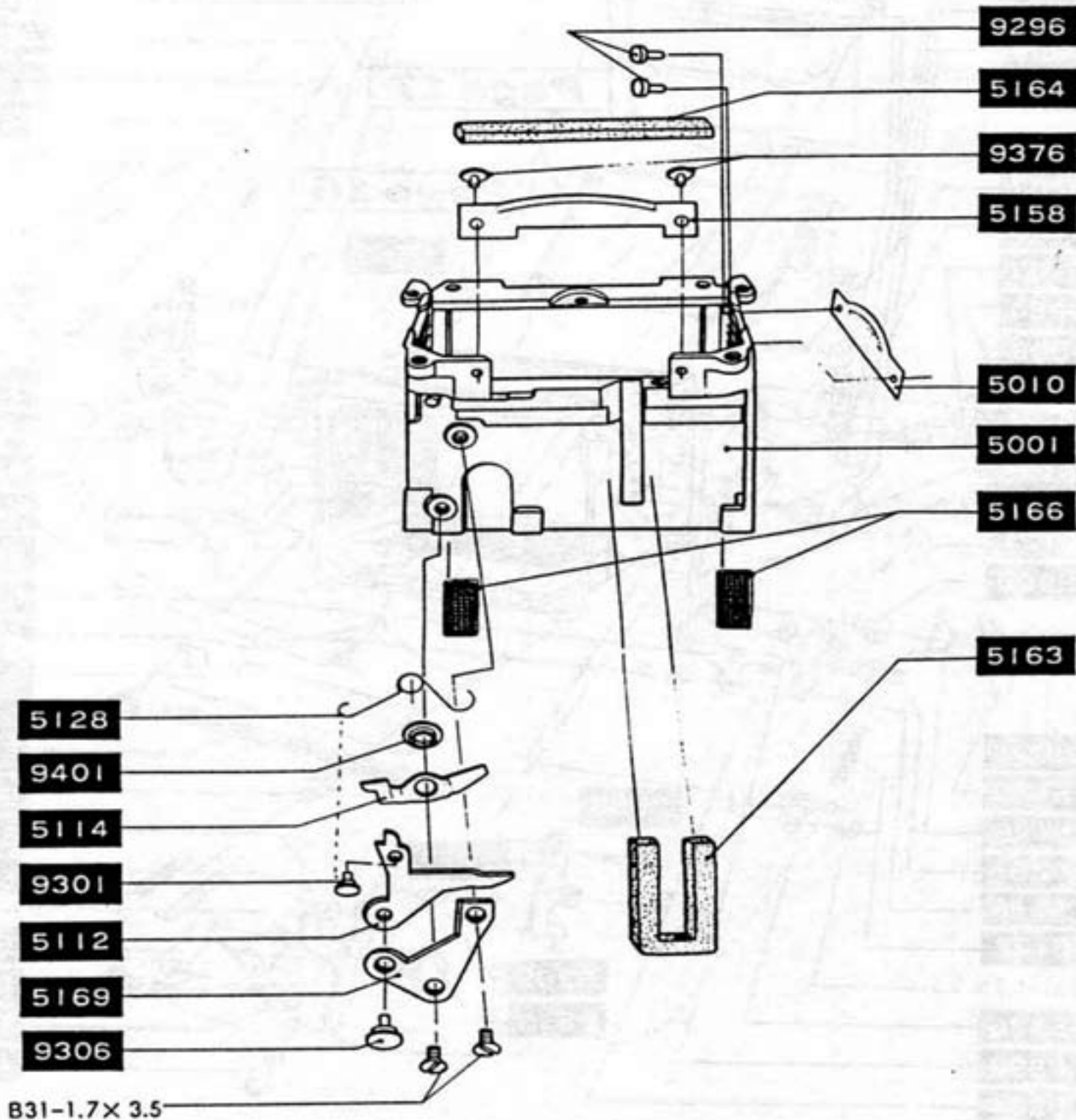

Complete set parts.

Key number 代表部品番号	Including parts number 結合部品番号
5001-71	5001, 5010, 5126, 5158, 5161, 5163, 5164, 5166, 9296, 9372, 9376, B31-1.7x2.5
5169-71	55169, 5112, 9301, 9306.

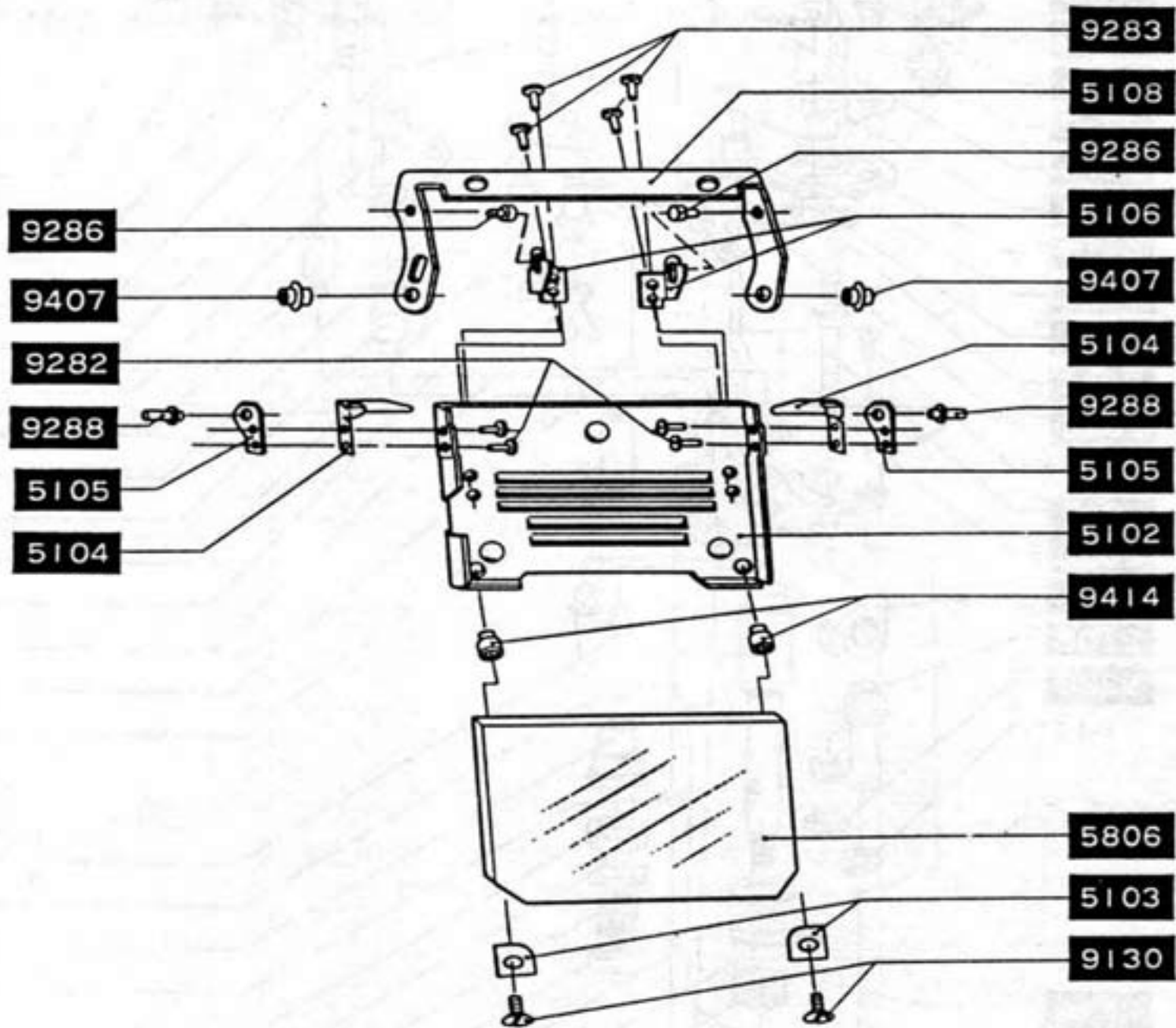

Complete set parts.

Key number 代表部品番号	Including parts number 結合部品番号
5102-71	5102, 5104, 5105, 5106, 9282, 9283, 9288, 9414.
5108-71	5108, 9286, 9407.

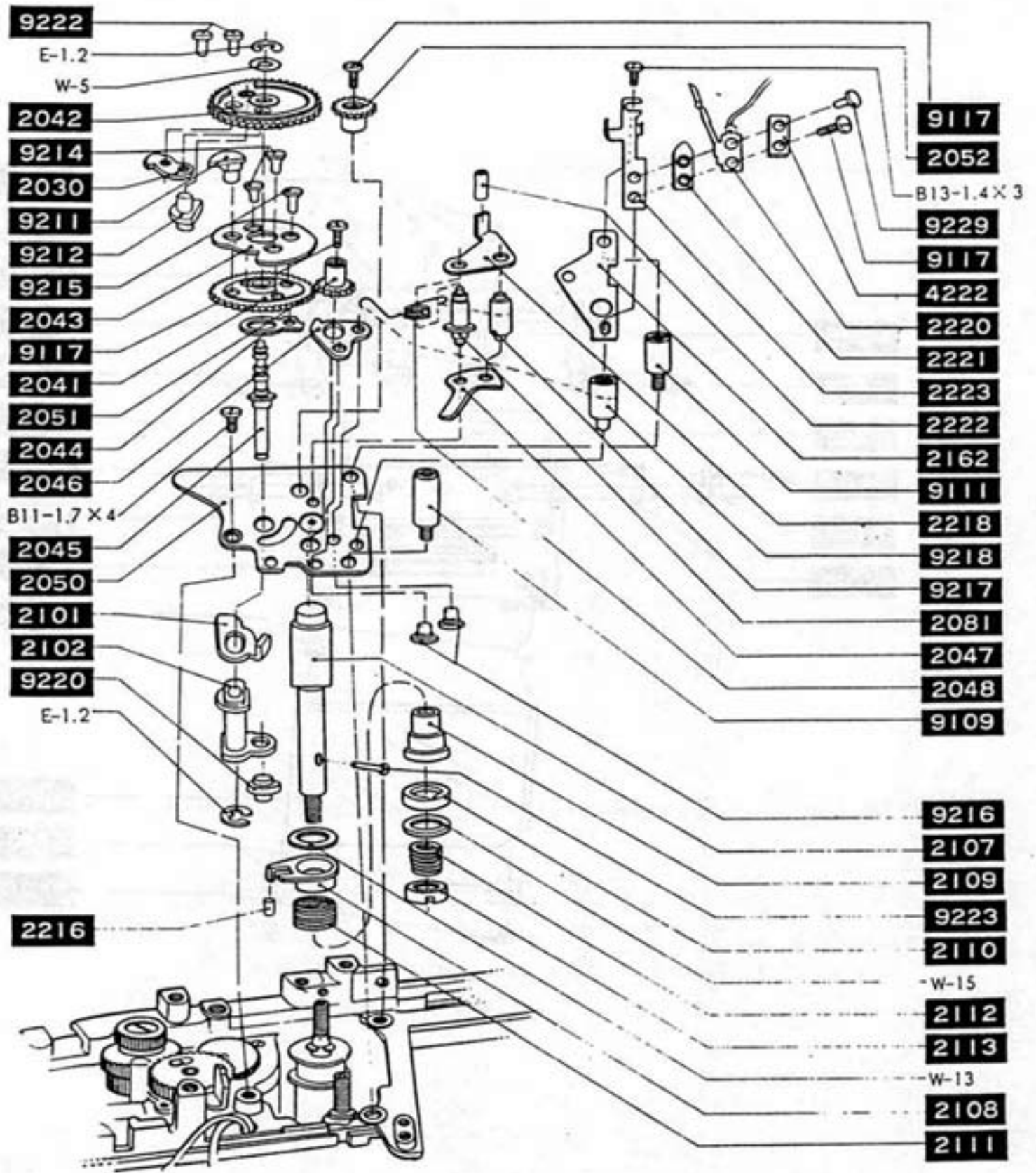

Complete set parts.

Key number 代表部品番号	Including parts number 結合部品番号
2041-71	2041, 2043, 2044, 9211, 9214, 9215.
2042-71	2042, 2030, 9212, 9222.
2047-71	2047, 2048, 2081, 2218, 2222, 9217.
2050-71	2050, 2045, 2046, 2107, 9216, 9218.
2101-71	2101, 2102, 9220.
2223-71	2223, 2220, 2221, 4222, 9229.

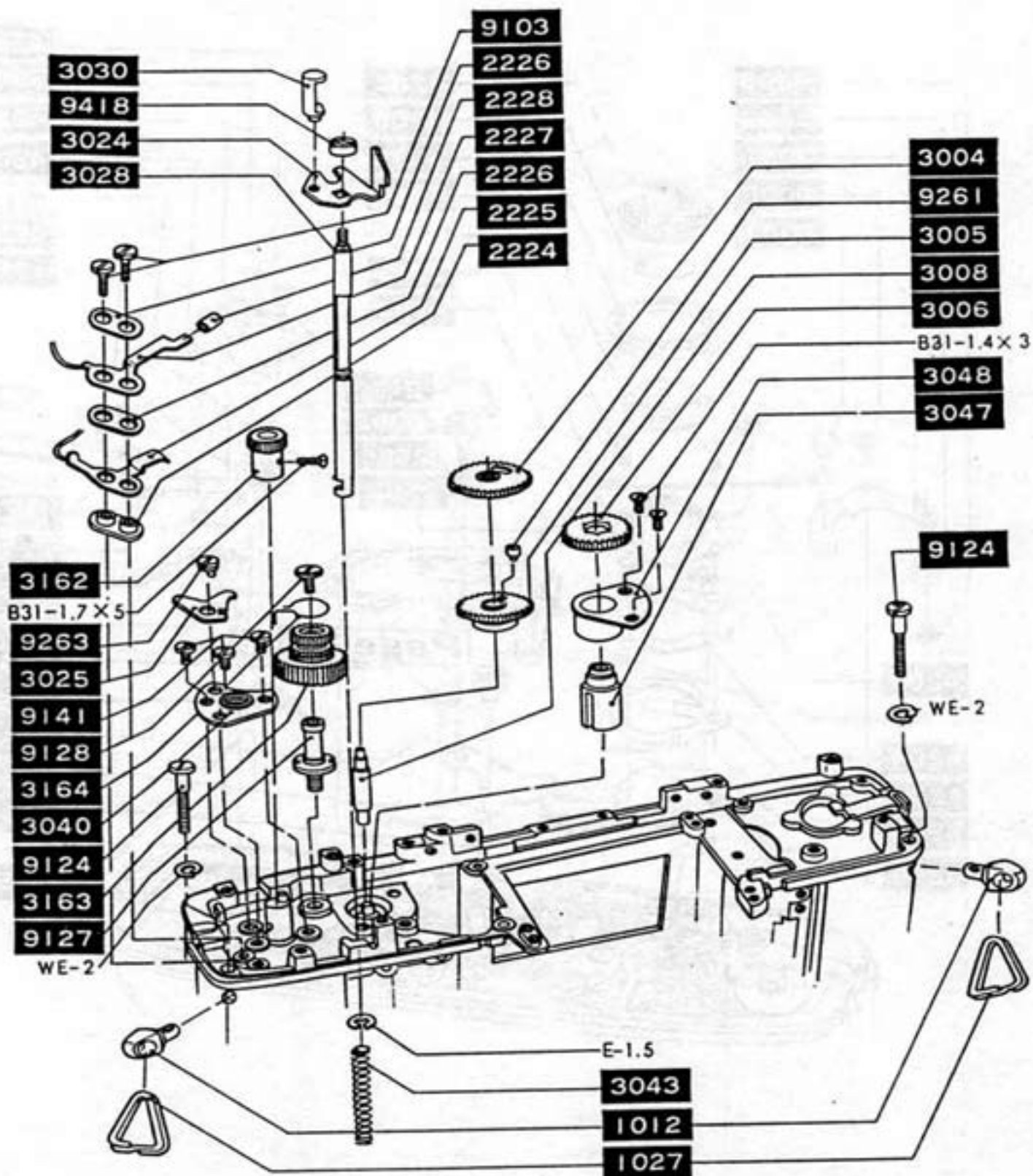

Complete set parts.

Key number 代表部品番号	Including parts number 結合部品番号
2224-71	2224, 2225, 2226, 2227, 2228.
3005-71	3005, 9261.
3024-71	3024, 3030.
3040-71	3040, 3025, 9263.
9418-71	9418, 3004, 3047

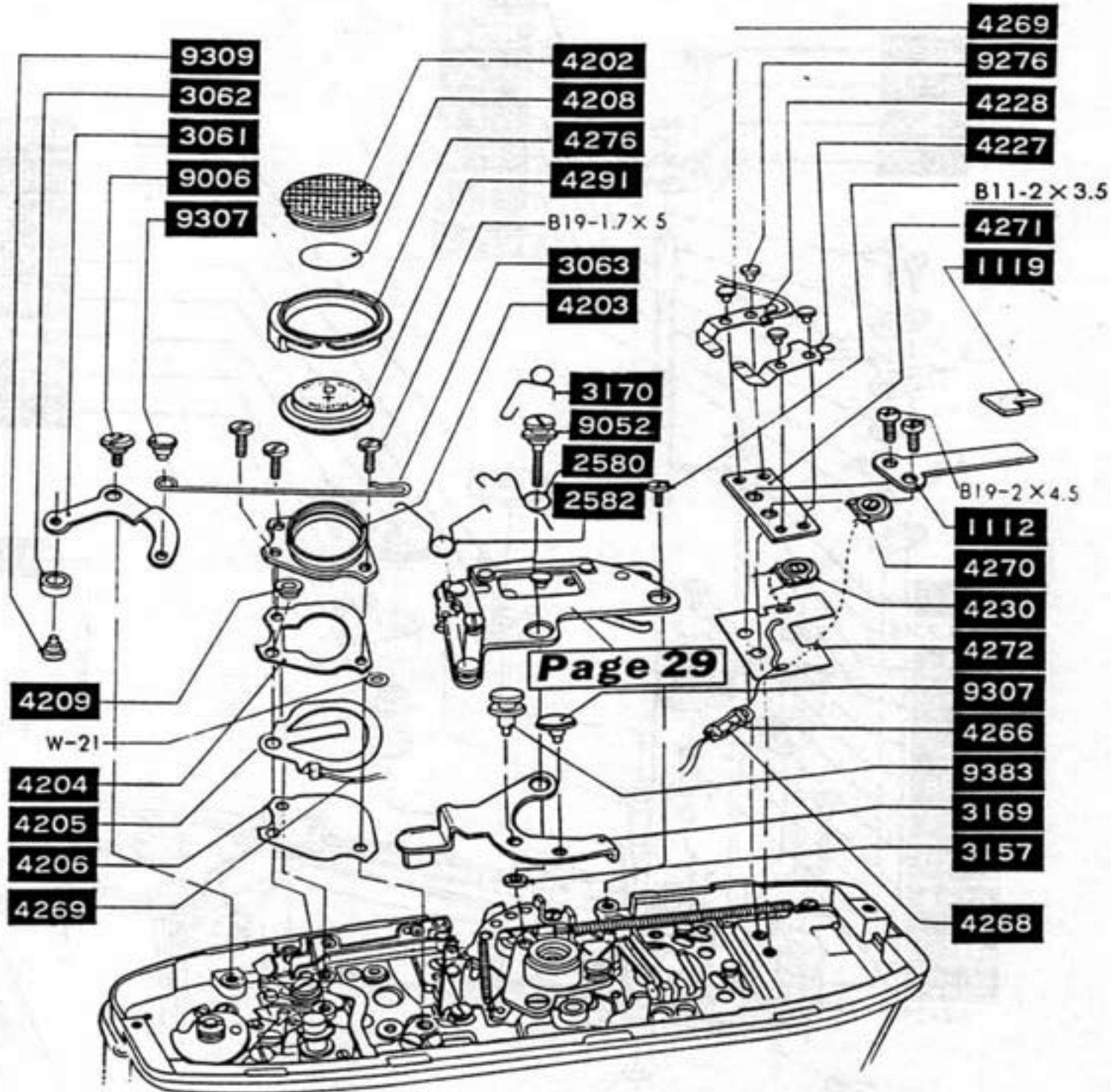

Complete set parts.

Key number 代表部品番号	Including parts number 結合部品番号
3061-71	3061, 3062, 3063, 9307, 9309.
3169-71	3169, 9307, 9383.
4202-71	4202, 4208.
4203-71	4203, 4204, 4205, 4206, 4209.
4271-71	4271, 4227, 4228, 4276.

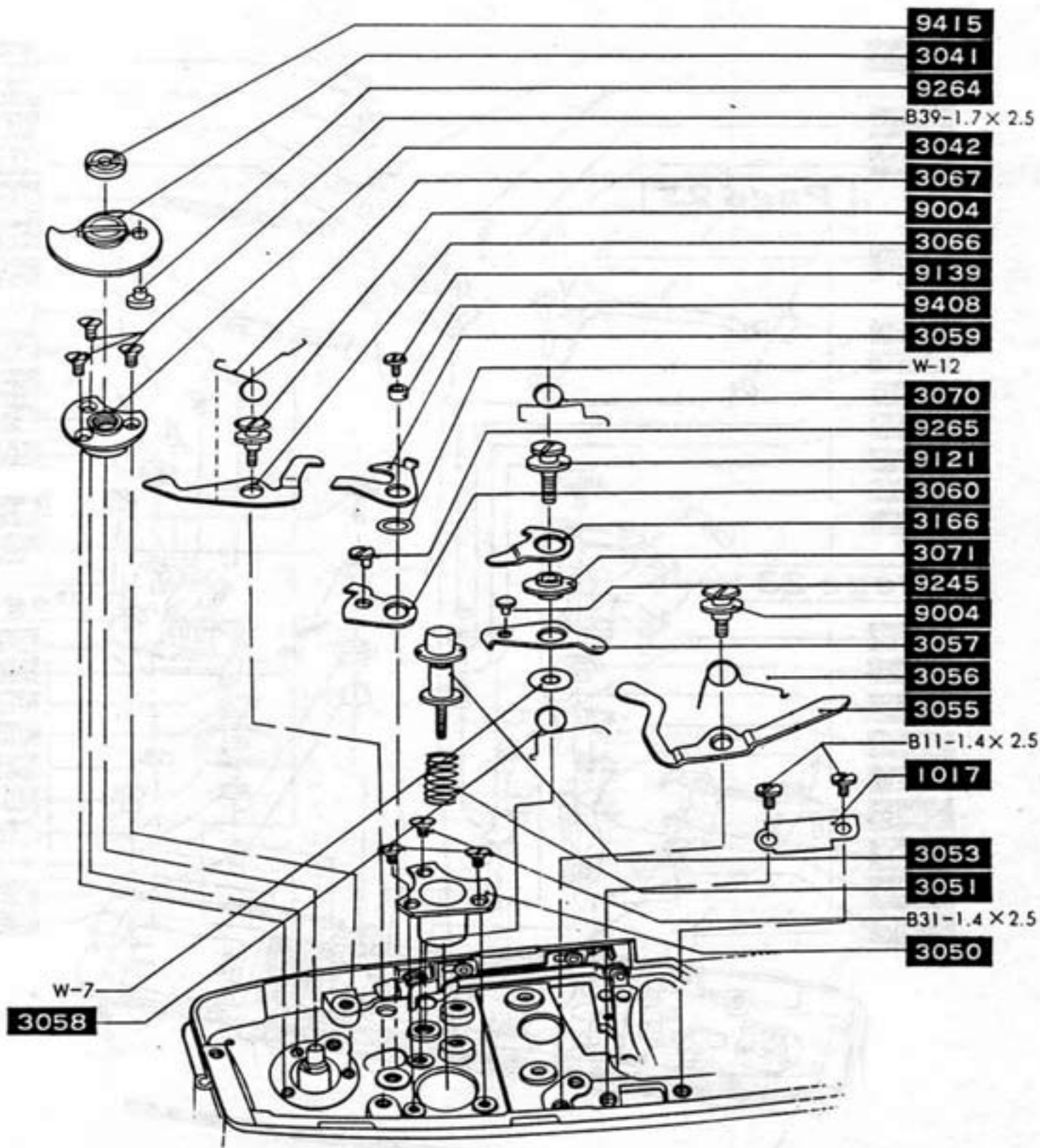

Complete set parts.

Key number 代表部品番号	Including parts number 結合部品番号
3041-71	3041, 9264.
3057-71	3057, 9245.
3060-71	3060, 9265.

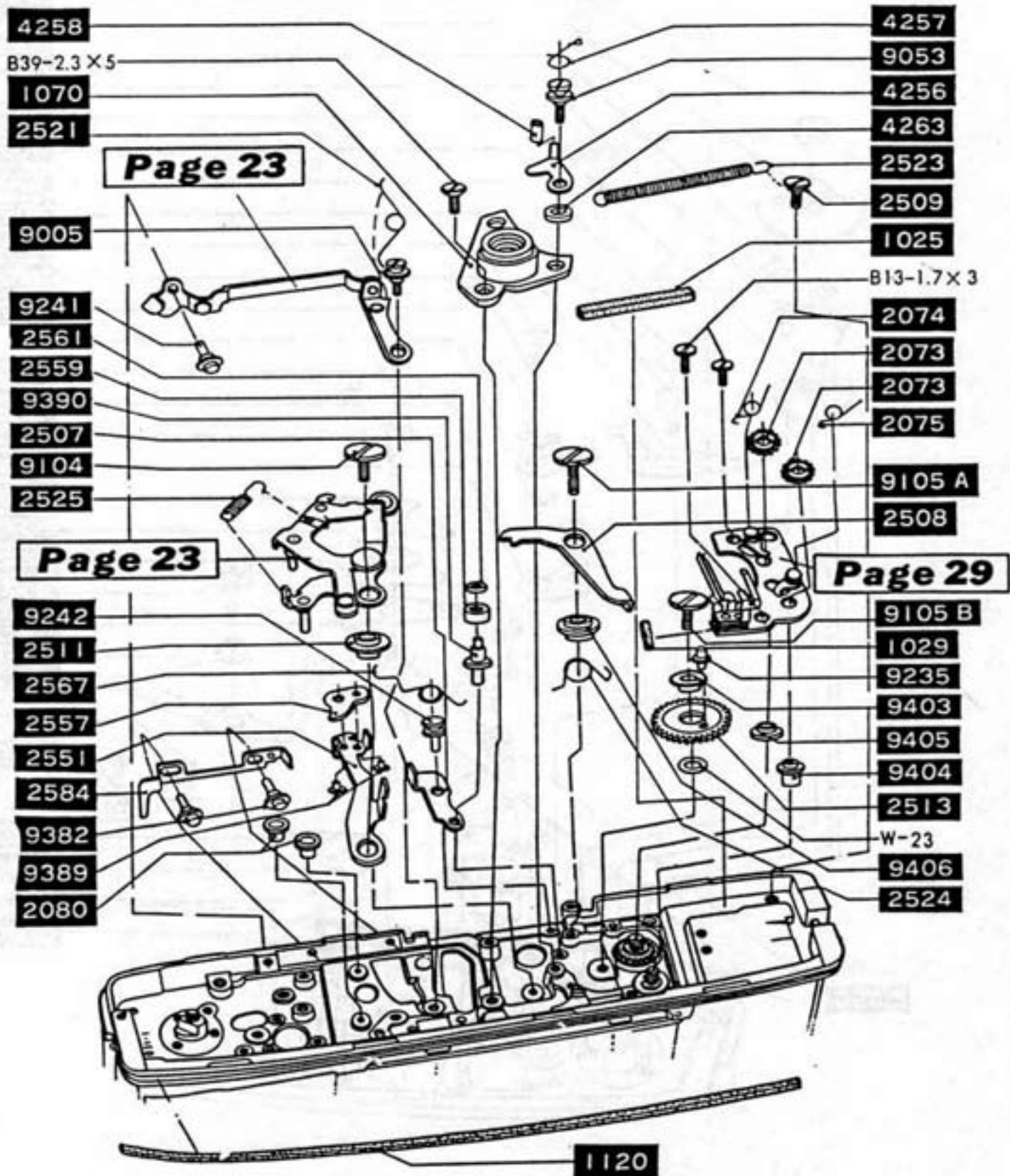

Complete set parts.

Key number 代表部品番号	Including parts number 結合部品番号
2551-71	2551, 2557, 9389.

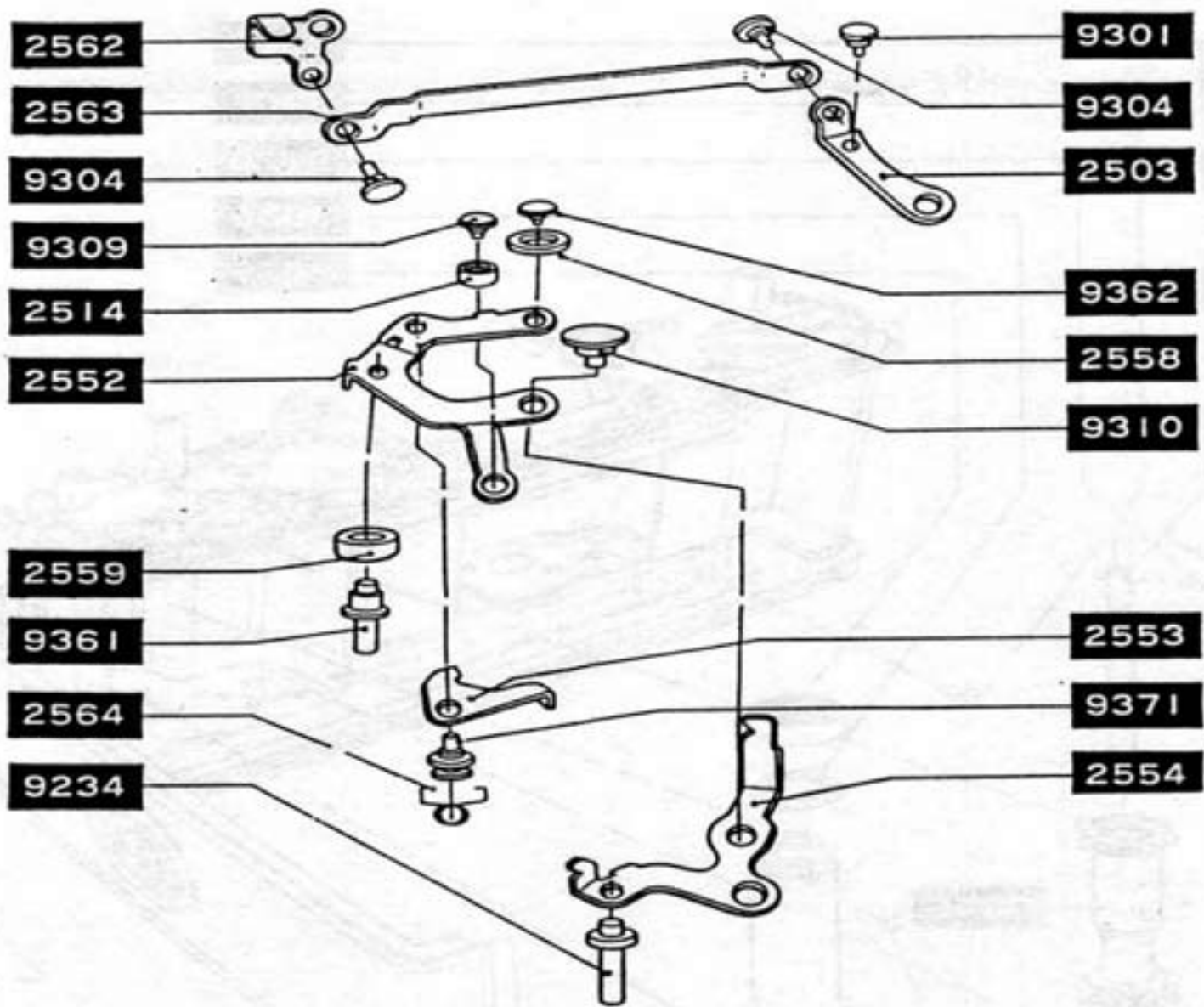

Complete set parts.

Key number 代表部品番号	Including parts number 結合部品番号
2552-71	2552, 2514, 2553, 2554, 2558, 2559, 9234, 9307, 9310, 9361, 9362, 9371, W-7.
2563-71	2563, 2503, 2562, 9301, 9304a, 9304b.

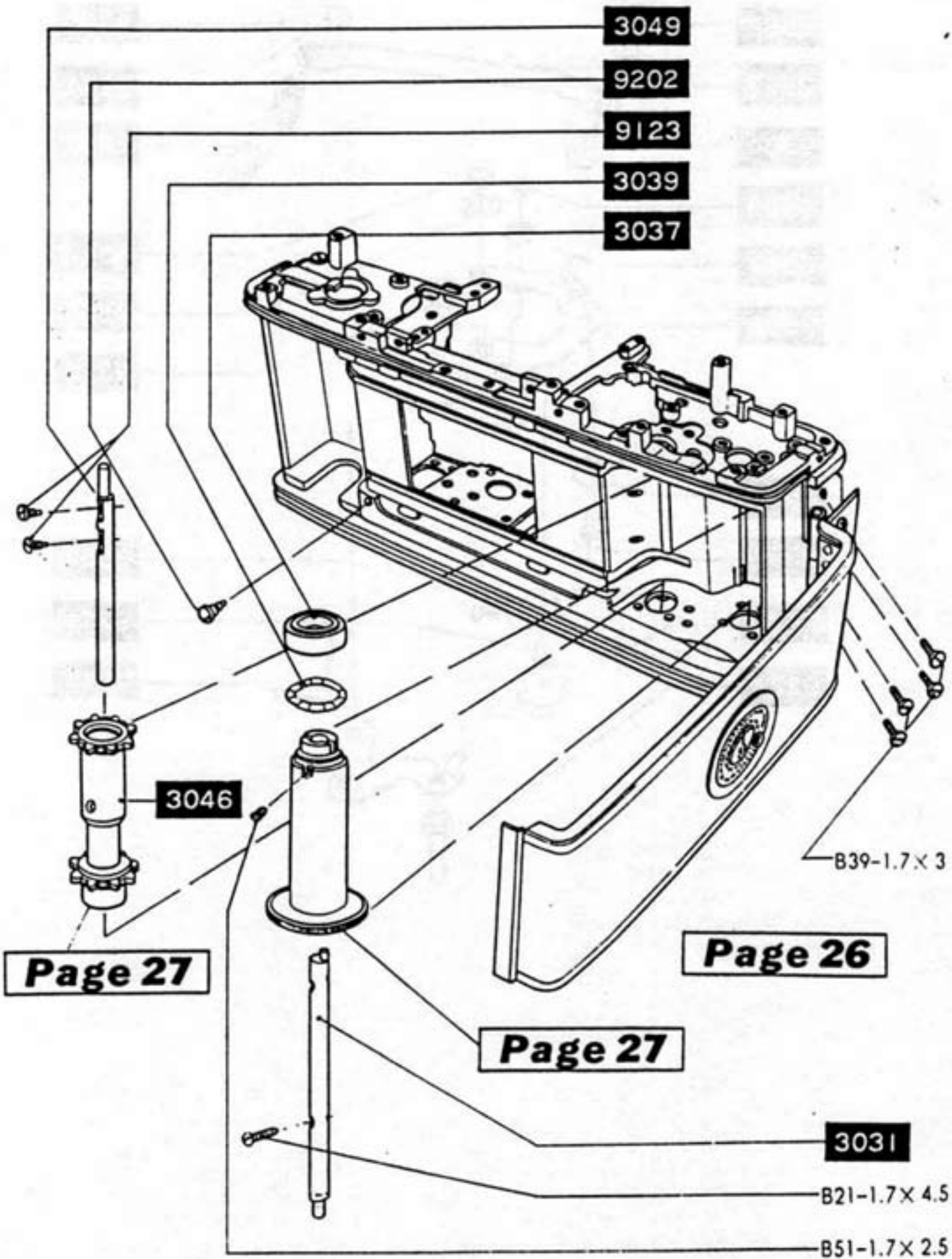

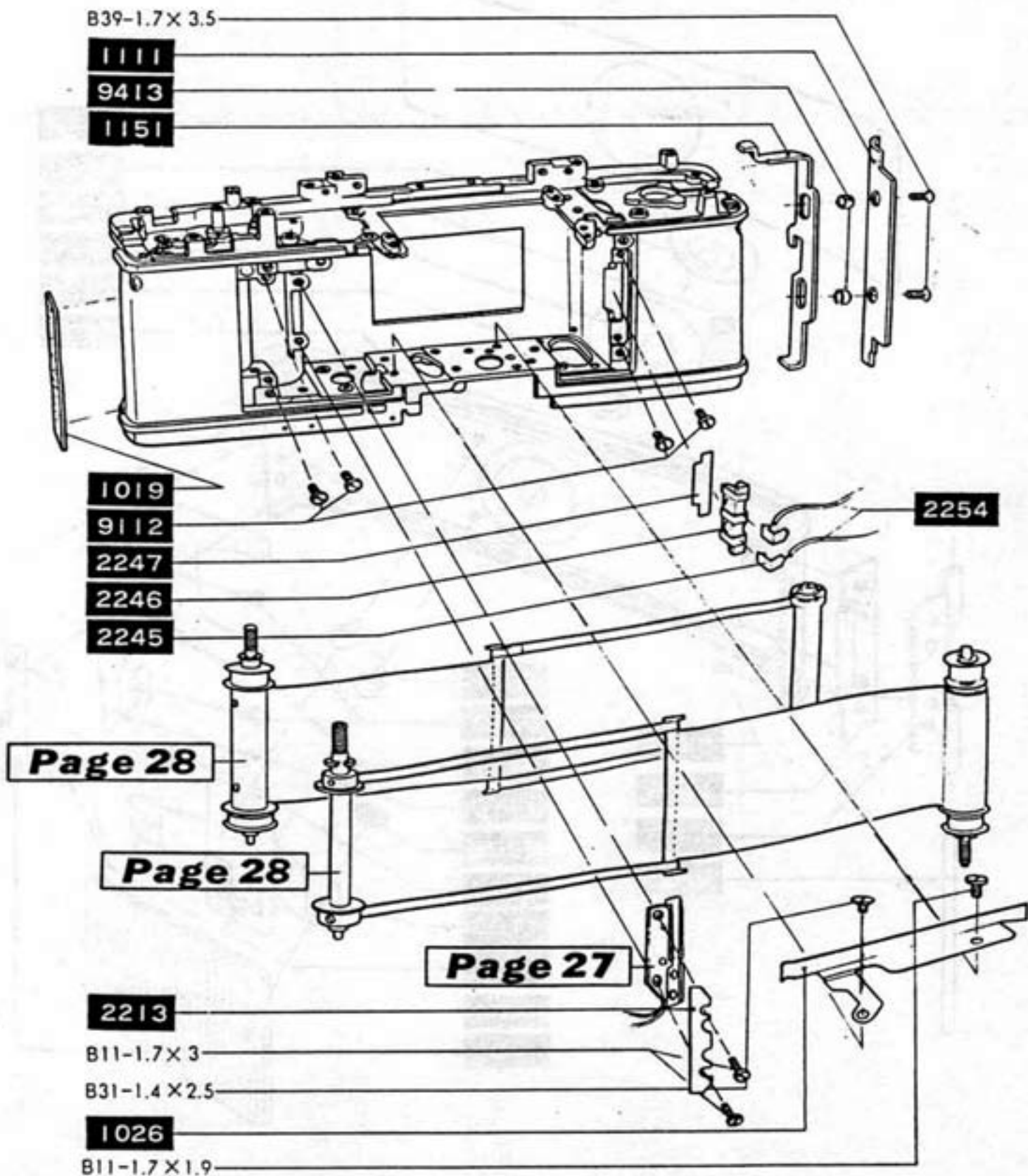

Complete set parts.

Key number 代表部品番号	Including parts number 結合部品番号
2246-71	2246, 2245, 2247.

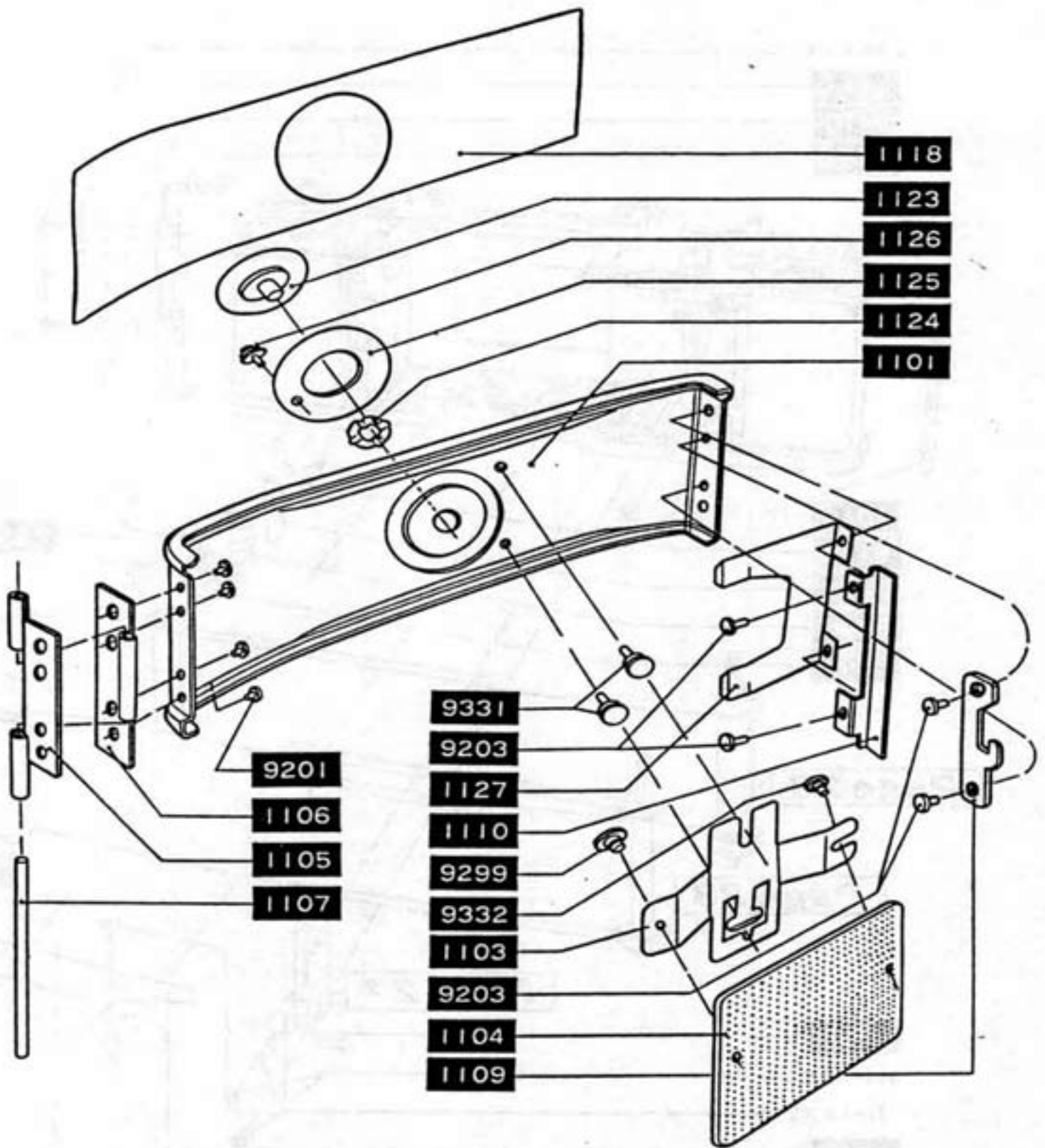

Complete set parts.

Key number 代表部品番号	Including parts number 結合部品番号
1101-71	1101, 1105, 1106, 1107, 1109, 1110, 1118, 1123, 1124, 1125, 1126, 1127, 9201, 9203, 9331.
1104-71	1104, 1103, 9299, 9332.

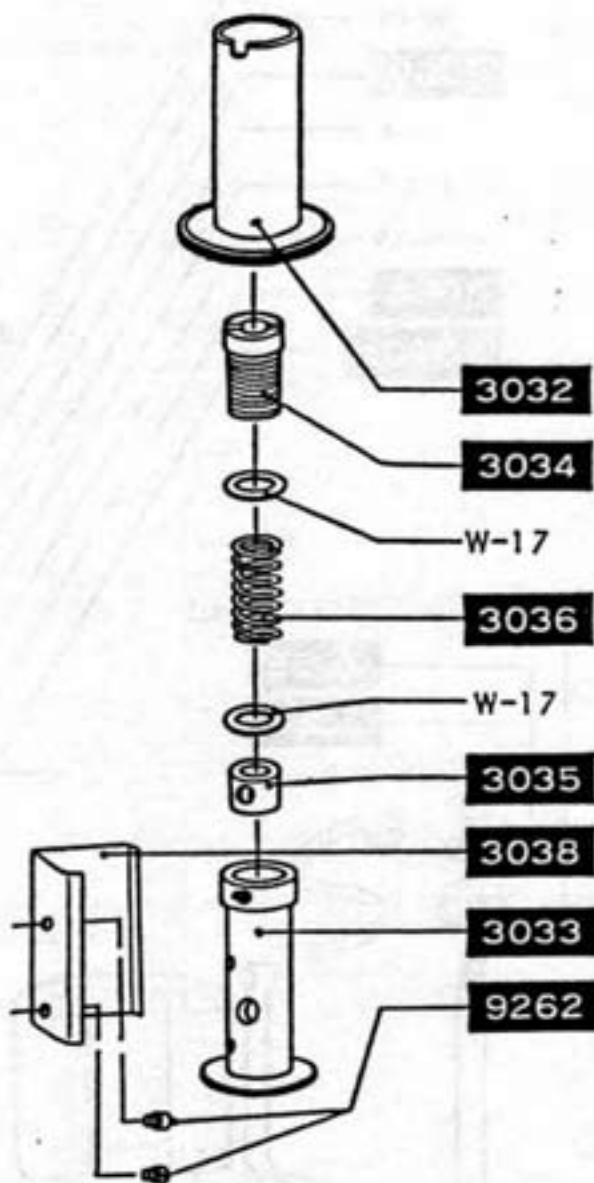
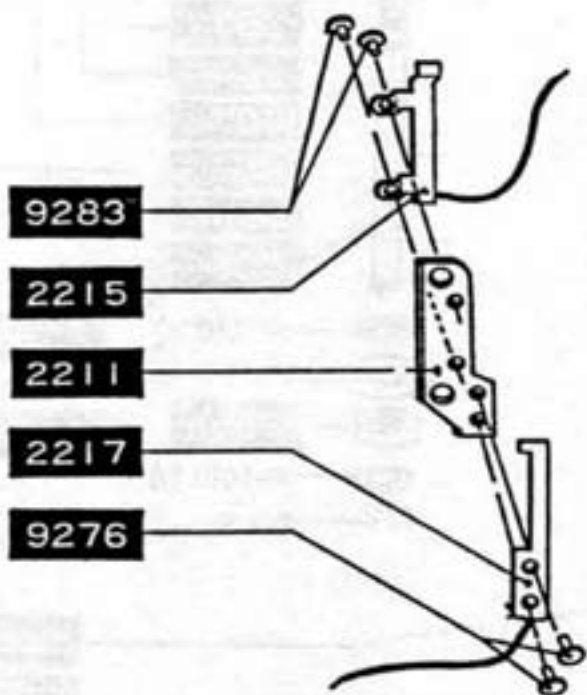
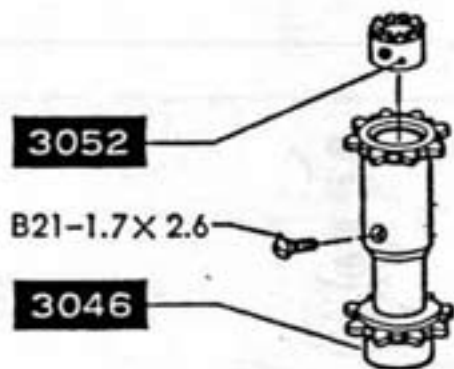

Complete set parts.

Key number 代表部品番号	Including parts number 結合部品番号
2211-71	2211, 2215, 2217, 9276b, 9283.
3038-71	3038, 9262.

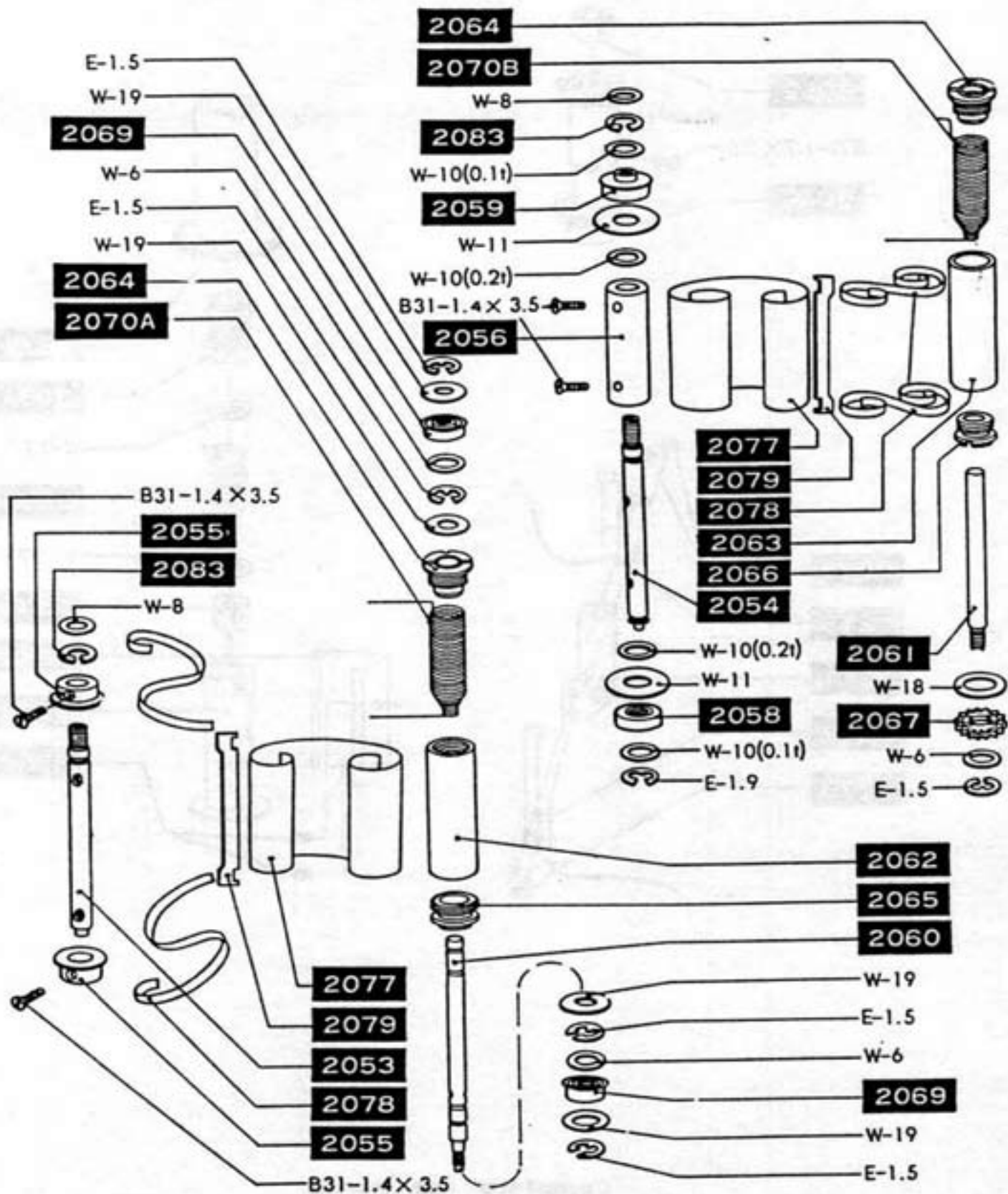

Complete set parts.

Key number 代表部品番号	Including parts number 結合部品番号
2077-71	2077, 2078, 2079.

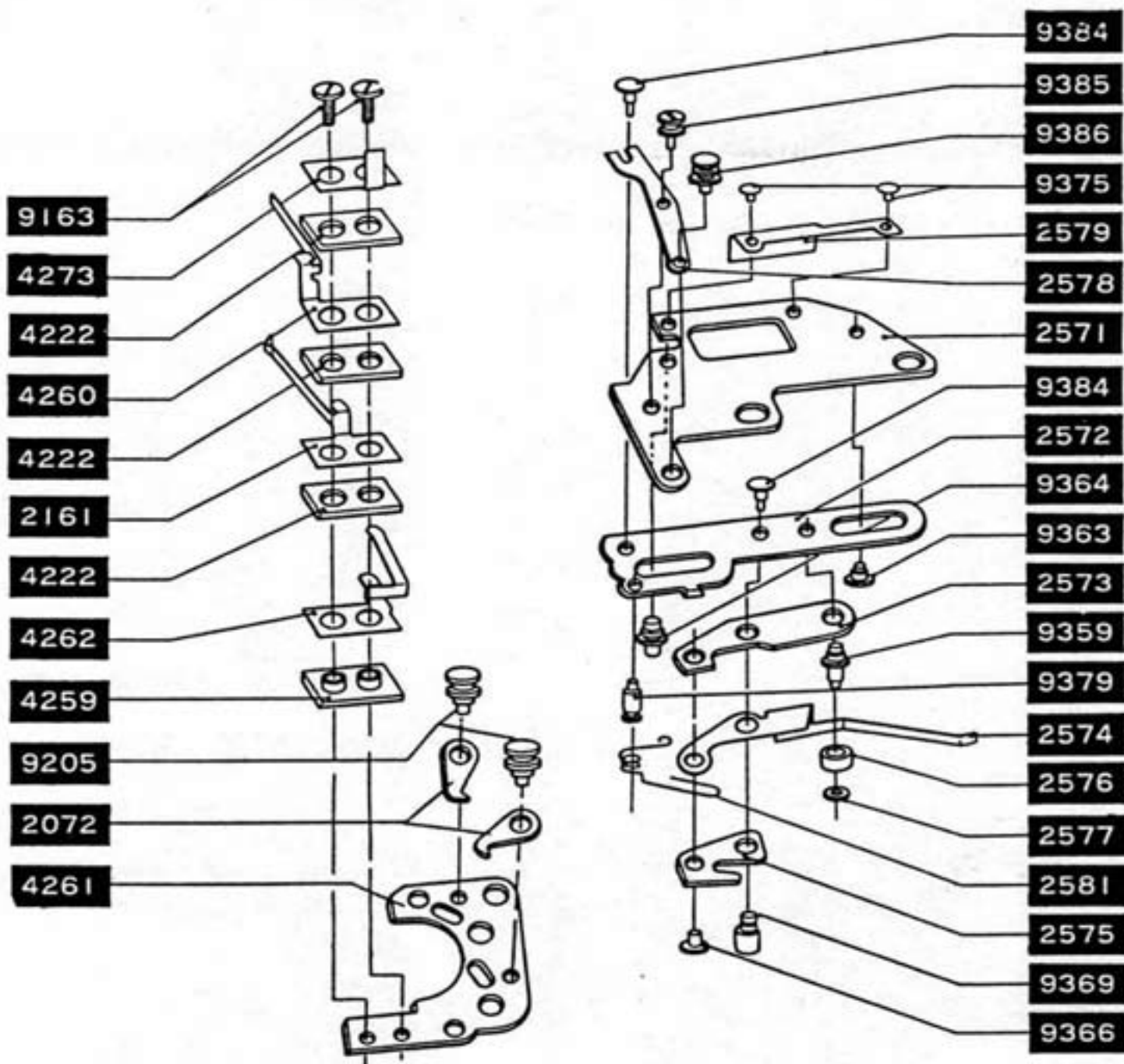

Complete set parts.

Key number 代表部品番号	Including parts number 結合部品番号
2571-71	2571, 2572, 2573, 2574, 2575, 2576, 2577, 2578, 2579, 9359, 9363, 9364, 9366, 9369, 9375, 9379, 9384, 9385, 9386.
2161-71	2161, 2072, 9205.